

1946

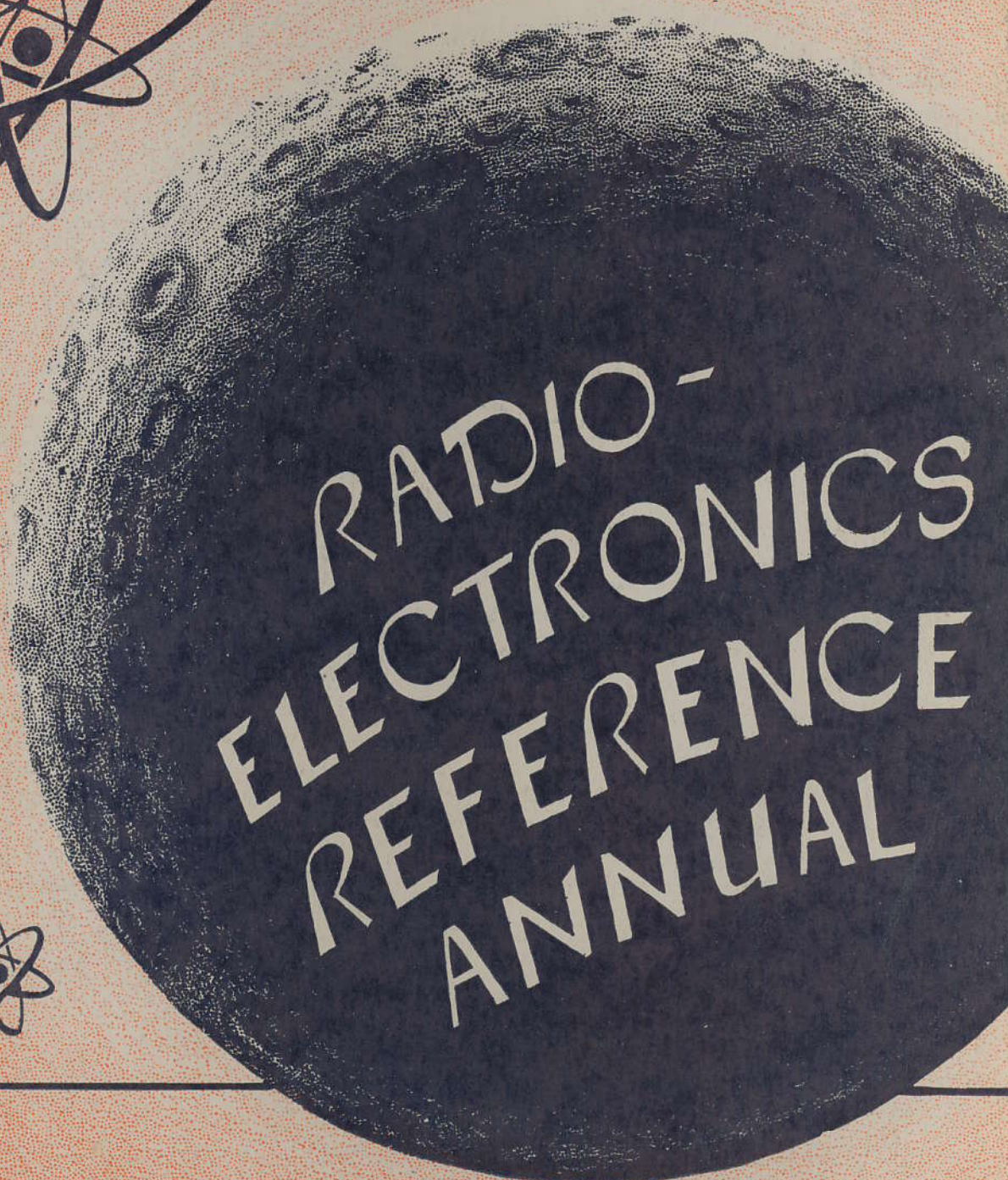

RADIO-  
ELECTRONICS  
REFERENCE  
ANNUAL



Published by

RADIO-CRAFT • 25 West Broadway • New York 7, N. Y.

# IRC PRESENTS



*the "Book of the Year"*  
**FOR SERVICEMEN**

Get your free copy from your  
IRC Distributor or write direct

## UP TO THE MINUTE DATA ON IRC RESISTORS

Every well-posted Serviceman will want his own personal copy of this new IRC Service Catalog. Profusely illustrated with useful charts, diagrams, tables and product pictures, it contains the kind of material a busy man likes to have right at his fingertips.

Among the interesting features in this catalog you'll find the complete story on the new smaller size BTS (1/2 watt) and BTA (1 watt) resistors, as well as useful data on the entire BT and BW resistor lines. Now in RMA Preferred Number Ranges as standard Dis-

tributors' stock, these quality resistors are quoted at new low prices.

Also included are pertinent facts on IRC's "Century Line" of volume controls . . . 100 controls that will solve over 90% of your problems in this category. But these are only the highlights of this helpful new catalog. You'll want to see and read it all.

Make sure that you get your copy by stopping in at your nearest IRC Distributor or, if more convenient, drop a card to Dept. RA

## International Resistance Co.

401 NORTH BROAD STREET, PHILADELPHIA 8, PA.



IRC MAKES MORE TYPES OF RESISTANCE UNITS, IN MORE SHAPES FOR MORE APPLICATIONS THAN ANY OTHER MANUFACTURER IN THE WORLD

# Contents

## THE CONSTRUCTOR AND DESIGNER

Public Address System .....	2
A Magnetic Recorder .....	6
Electronic Metronome .....	12
A Pen-and-Ink Recorder .....	22
Two-Tube FM Receiver .....	28
Wired Radio in Two Units .....	29
1-Tube Metal Locator .....	30

## SOUND AMPLIFIERS AND INSTRUMENTS

Electronic Guitar .....	4
Economy 20-Wattter .....	13
Fixed-Bias Amplifiers .....	18
A Novel Feature in P.A. Systems .....	20
A Compact Amplifier .....	36
Australian Champion .....	36

## THE SERVICEMAN AND MECHANIC

Remote Juke Boxes .....	7
Station Riding .....	9
Record Changers .....	27

## PRACTICAL TEST INSTRUMENTS

Signal Tracer-Plus .....	8
Capacitester .....	14
Dynamic Tube Tester .....	21
Capacitor Checkers .....	24
Electronic Multichecker .....	42
Better Signal Generator .....	43

## THE TECHNICIAN'S DEPARTMENT

How to Track the Superhet .....	10
Matching Loudspeakers .....	15
Measurement of Capacity .....	16
Transmission Lines .....	23
Cross-Over Networks .....	31

## PRACTICAL RADIO RECEIVERS

New Idea in Detector Circuits .....	11
Ultra Radio .....	19
Short-Wave Interflex .....	25
Two Cigar Box Radios .....	26

## SHORT CIRCUITS AND WIRING KINKS

Neon Checker from Old Parts .....	26
A Chassis Cradle from Pipe Fillings .....	44

# Public Address Relay System



A completely portable pickup unit which can be moved rapidly and without the accompaniment of trailing wires is indeed a useful device in public address pickup of outdoor events. The unit shown at the left— together with its designer and the author of this article, Mr. Cornish— is such a pickup and retransmitting station. It has considerably more output than the pack-type sets used in convention halls, and gives excellent results over distances of more than three hundred feet. Such ranges are usually near the practical maximum in public address work.

**E**VERY radio man who has had any part in the setting and operating of sound equipment at field-meets, football games and other public events where large crowds are present has been confronted with that ever-present problem of having someone trip over the microphone cable.

The writer has followed the sound business for past fifteen years and personally encountered these cable difficulties. He conceived the idea of eliminating the cable entirely by using a small low power transmitter, powered by batteries, and carried by the announcer. This relays his voice to a special receiver pick-up, located near the public address amplifier.

The output from the receiver is fed into the amplifier and after amplification delivered by the loud-speakers so that all present may hear.

A request was made to the FCC at Washington for permission to carry on some experiments in this field with a transmitter of suitable power, but they immediately turned thumbs down on the request, stating that no such service had ever been authorized.

## RADIO STATION W8XWI

A two-year correspondence finally resulted in a hearing and the writer appeared before them with a full description of the new service he desired to establish.

About three months later a construction permit was granted for a small transmitter to operate on 310 megacycles with an out-

put which was not to exceed one watt total.

After construction was complete, a class II experimental license was granted and the call letters W8XWI were assigned to the station.

The first transmitter placed in this service was built in pack form and carried on the back of the announcer.

While the operation of this equipment was satisfactory as long as the crowd remained at a distance from the announcer, when they crowded around him the UHF signals were absorbed to such an extent that the loud-speaker volume would fall below suitable levels.

To overcome this difficulty the transmitter was mounted on a tripod and the antenna changed to a fork or end-fire type, which being directional, permitted the beaming of the signals to the receiver.

Another advantage gained by this arrangement was the fact that the antenna was well above the heads of the people and the shifting of the crowd did not affect the signals.

This station with a wave-length of a little less than one meter, operates on what is known as line-of-sight transmission and best results are obtained when the path between the transmitter and receiver is free from obstruction.

The question usually asked is, how far will the signals carry? This can be answered by saying that in ninety-five percent of all occasions where this outfit is used, the distance covered is less than three hundred feet.

In any type of sound service where loud-speakers are located three hundred feet from the microphone, the time required for the sound to travel through the air from the speakers to the mike gives the impression of an echo. This is very annoying to the announcer and for this reason every attempt is made to keep this distance as short as possible.

On one occasion where the announcer was covering an athletic contest on a recreation field, a clump of bushes stood between him and the receiver and the radio waves were absorbed or reflected to such an extent that satisfactory operation was impossible. When the antenna was turned in such a way as to direct the waves against the recreation building at an angle, the reflected waves reached the receiver and perfect results were had from the loud-speakers.

On another occasion it was found that the waves when striking a concrete wall at an angle were reflected, but when striking squarely they penetrated the three foot thick wall and operated a public address system inside the building.

The transmitter will deliver about one-half watt when two 958 acorn tubes are used with 135 volts on the plates. With two 955 tubes using 180 volts on plates, an output of about three-quarters watt can be expected.

## FREQUENCY STABILITY

This station, small as it is, comes under the regulations of the FCC and must be handled by a licensed commercial phone operator.

The FCC requires some means of frequency control on all transmitters and for those working on frequencies above 300 megacycles probably the best method is the use of tuned lines in both the plate and cathode circuits.

If these are rigidly constructed and well insulated, the frequency will remain constant over long periods of time. Their appearance and relative positions are easily seen in the two photographs.

One precaution must be taken in mounting the porcelain insulators to the aluminum chassis. If these are screwed down tight, the chances are they will crack and the copper tubes will not be held rigid enough to insure frequency stability.

The best way to prevent this, is to cut a piece of felt the shape of the base of the insulator and place it between the insulator and the aluminum chassis before tightening the screws. Any variation in the porcelain caused by temperature changes will be taken up by the felt pad and damage to the insulators avoided. These precautions must be taken, as frequency can be varied

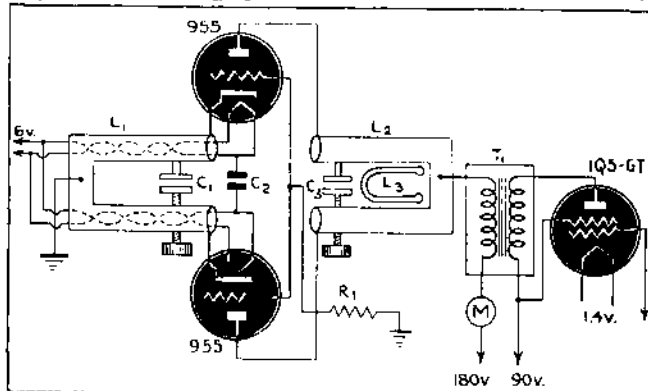

Fig. 1—The transmitter uses a standard transmission-line circuit

only too easily at the frequency used.

The chassis is formed from a one-sixteenth inch aluminum sheet by bending it over a wooden block. It measures two inches high, four and one-half inches wide and ten inches long. The circuit is shown in Fig. 1.

The plate tubes are made from hard-drawn copper tubing, sixteenth-inch wall and outside diameter, three-eighths inch. They are spaced three-quarters inch between centers and are four inches long.

The plate tuning condenser is the usual two plate type, one of the plates fixed to one of the tubes and the other soldered to a machine screw, which is threaded through the other tube so that the distance between them can be varied by turning. These plates are three-quarters inch in diameter.

The two acorn sockets are mounted at one end of the chassis and each plate tube is connected by a short stout wire to the plate spring on each socket.

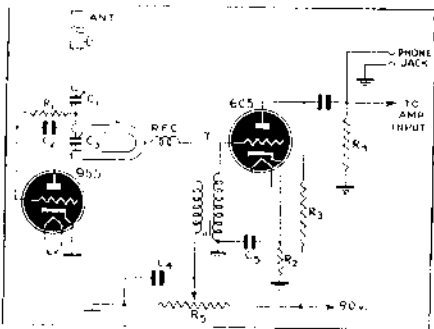

Fig. 2—Receiving unit of the relay system.

The far end of the tubes are connected by a heavy copper yoke, supported on a porcelain insulator.

The two grid leads on the acorn sockets are connected together and then grounded to chassis through a 25,000 ohm resistor.

At the opposite end of the chassis is shown the modulator transformer and IQ5GT.

The cathode tubes are mounted under the chassis and are identical in size and spacing to the plate tubes with the exception of the length, which is seven inches.

The cathode tuning condenser is constructed the same as the plate condenser but the diameter is one-and-one-half inches.

Between the acorn sockets is a small condenser, useful in tuning the filaments when 958 tubes are used.

The two condensers, variable by screwing in and out the threaded rod connected to one plate, make tuning up—which is done in conventional manner—easier. A hairpin loop, L<sub>2</sub>, mounted in the plate coil, furnishes coupling to the antenna.

If a carbon microphone is used, one end of the microphone transformer secondary is connected to the grid of the IQ5GT tube and the other end is grounded to chassis.

## TWO-TUBE RECEIVER

The receiver pick-up, removed from its case, is shown in the photograph, also its two cables. Fig. 2 is the schematic of this

unit. The one with a four prong plug plugs into the side of the public address amplifier to draw filament and plate current and the other cable with a phone plug feeds the signals into the amplifier input jack. (Cable connections are not shown in the schematic.)

The dimensions of this receiver pick-up can be roughly judged by noting the size of the phone plug. There is, however, no crowding, and the efficiency of the receiver is in no way reduced by its extreme compactness.

On the front panel are shown two knobs, the bar knob on left controls the plate voltage on the 955 detector and the knob on right is the tuner.

The jack at bottom of panel is for head-phone reception when necessary.

The amplifier is shown in Fig. 3 Input may be either from the receiver or a microphone.

While a carbon microphone may be used in some classes of service, where the crowds are large and the noise level high, a good crystal microphone will give far better results.

Unfortunately the output from a good crystal mike is low and it must be built up before it can be fed into the modulator tube.

For this purpose, a two-tube speech amplifier is required and a circuit diagram is shown, also a photograph of the one used in these experiments.

A volume control enables the operator to control feed-back when operating at various distances from the loud speakers. As the equipment is used almost entirely out-of-doors, this problem is not nearly as serious as in many P.A. installations, though care must be taken in certain set-ups.

The microphone used in these experiments is the Turner model 22X with tilting head. The tilting head feature makes it perfect for interviewing, as the head can be turned back and both sides of the conversation received.

Originally this was considered as merely an experimental model and a base for further development, but for nearly a year the writer has been instructing in radio and mathematics at the Fifth Command Signal Corps School, in Cincinnati and during this

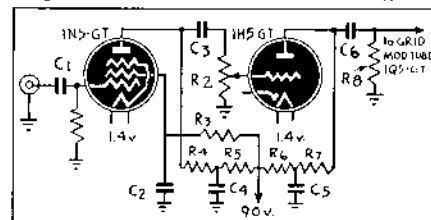
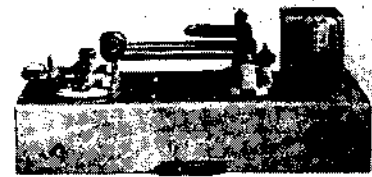
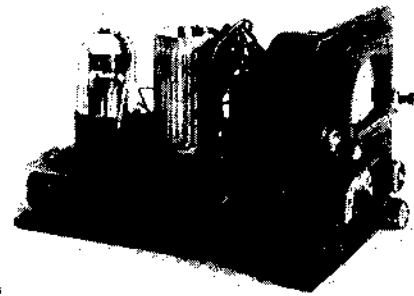

Fig. 3—Speech amplifier uses high-mu tubes.

period has had no time to do experimental work of any kind.

However, as the equipment operates very well in its present state of development, this detailed description of same may be of interest.



Top—Speech amplifier; bottom—transmitter.

## List of Parts Used in Oscillator and Modulator

- L—Cathode line, 3/8 inch O.D. copper tubing seven inches long
  - L—Plate line, 3/8 inch O.D. copper tubing four inches long
  - Both cathode and plate lines are spaced 3/4 inch between centers
  - L—Copper antenna loop 1 inch wide and 2 inches long
  - C—See text
  - C—See text
  - R—I.R.C. 25,000 ohm, 1 watt resistor
  - C—See text
  - M—Triplett 0-50 ma. meter
  - T—Thordarson small modulation transformer.
- Note: In addition to above parts, Johnson insulators were used throughout all three units and Eveready batteries were used to power the transmitter.

## List of Parts Used in Receiver Pick-up

- ANT—1/4 inch brass roll with sliding sleeve. The length can be varied from 15 to 25 inches
- C1—National type M-30 mica condenser
- R1—I.R.C. 5 megohm 1/2 watt resistor
- C2—Cornell-Dubilier .00025 mica condenser
- C3—National type UM, cut down to three plates
- L—No. 6 copper wire bent as shown, 1/2 inch wide and 1 1/4 inches long
- RFC—15 turns No. 20 DCC copper wire, close wound in one layer and bound with collodion
- T—Thordarson T-13A34 transformer
- C4—Sprague 1/2 mfd. paper condenser
- C5—Sprague .1 mfd. paper condenser
- R2—I.R.C. 2500 ohm 1 watt resistor
- R3—I.R.C. 100,000 ohm 1/2 watt resistor
- R4—I.R.C. 1 megohm 1/2 watt resistor
- R5—Electrad 50,000 ohm volume control

## List of Parts Used in Speech Amplifier

- C1, C2, C3, C4, C5, C6—Sprague .05 paper condensers
- R1—I.R.C. 3 megohm 1/2 watt resistor
- R2—Electrad 200,000 ohm volume control
- R3, R8—I.R.C. 1 megohm 1/2 watt resistor
- R4, R7—I.R.C. 100,000 ohm 1/2 watt resistor
- R5, R6—I.R.C. 25,000 ohm 1/2 watt resistor

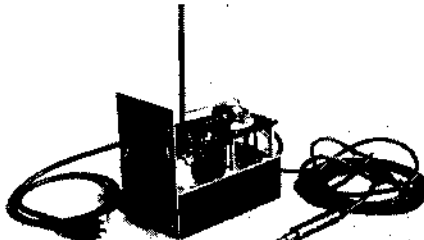

Complete radio P. A. system. Left—Speech amplifier; center—receiver; right—transmitter.

# ELECTRONIC GUITAR

The electronic music enthusiast will find this instrument well worth the time and effort required to build it. The sturdy unit requires less meticulous attention to detail in construction and adjustment than other types which use smaller parts. An amplifier is shown, but any high-fidelity amplifier should work well if carefully built and adjusted.

**E**LECTRONIC musical instrument amplifiers for electric guitars have been described by the dozen, ranging from high quality down to "junk box" super-duper amplifiers. However they rarely finish the job by giving complete instructions on how to make the guitar, as well as the amplifier. Following are a few constructional suggestions founded on a sad experience of tedious experiments both with the amplifier and the pick-up device, simplification of the latter being the greatest obstacle.

The main objective is, of course, to produce an instrument that really looks and performs like a commercial article. The compromise between portability and power output is always a stickler, but when it's boiled down it will be found that an amplifier of the size shown is quite portable, with no sacrifice of tone or power because of a small junky chassis and speaker.

The guitar itself is made of solid birch or some other hard wood. A soft wood can be used and may be easier to work with but it is impossible to keep the dints out of it. A soft wood also tends to vibrate with the strings, causing extraneous pick-up of objectionable noises. The body is shaped very smooth using a power sander except in tight corners, of course. If you do not have power tools don't let it bother you, for it is surprising how little it costs to have it done. There are two output plugs on the end of the instrument. The extra one is for use with an extra foot volume control, if desired.

The finish should be a high grade varnish, two coats, rubbed down with rottenstone. If you don't feel capable of the job by all means have it done by a professional, as it is well worth the four dollars which it costs to get the mirror like finish. The fret markings are made carefully at right angles to the centre line of the instrument; the exact measurements of the frets may be copied from an ordinary Hawaiian guitar.

Masking or adhesive tape placed 1/16" apart on either side of the fret marking line produces a smooth, straight and well defined line when filled with a quick drying white enamel of fairly thick consistency. The markers for the "main" frets are small rhinestones taken from a dime store brooch and set in countersunk holes of the proper size with cement. The bridge should be made so that the tops of the strings are level, especially the third or "A" string, in order to avoid undesirable scraping and buzzing noises while playing. The "nut" at the other extremity should of course be bought with this point in mind. The tail piece to which the strings are anchored is made of a standard one cut down, drilled and bent to fit. The physical contours of the guitar may be altered to suit personal tastes as desired. This has no effect on the tone of the instrument. To complete the guitar a zipper fastened canvas case may be made, not forgetting a side pocket for the connecting cable, plugs, picks and other playing accessories.

## THE ELECTRONIC PICK-UP

The pick-up device or unit is the heart of the instrument. It is the most interesting

and neglected part in constructional articles. Its operation is based on the theory of magnetic lines of force inducing a current in a

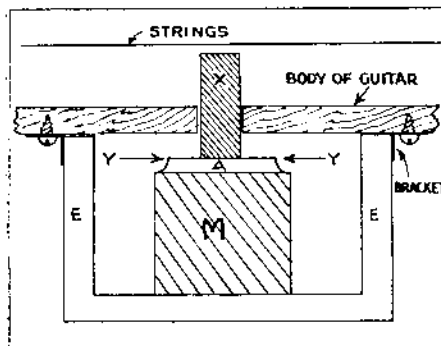

Fig. 1.—The unit in its place under the strings.

conductor moving through the magnetic field. In this case things are reversed; the conductor, which is in this case the coil, remains stationary and the magnetic field moves in accordance with the disturbances caused by the steel strings vibrating in this magnetic field. The strength of the generated signal depends on

- (a) Intensity of magnetic flux or field.
- (b) Size of wire in coil.
- (c) Proximity of the vibrating body, i.e. strings, to the magnetic field. It should be mentioned here that magnetized strings are NOT used.

The pick-up unit proper is constructed from a discarded 5" P.M. speaker having a fairly powerful magnet, usually of the new "Alnico" type and having a U shaped field extension, and *not* one of the pot shaped types.

Shown in Fig. 1 is a diagram illustrating the relative positions of the pick-up magnet, strings and coil. A polished metal panel is used to cover the opening in the back of the guitar through which the unit is installed. It is easily accessible without removing the strings. Fig. 2 shows the shape of the speaker magnet and the relative position of the coil. The dotted lines show the portion of the speaker frame assembly which should be removed with a hacksaw. Use of a magnet of this shape (cylindrical) provides a particular advantage in that construction of the coil is reduced to simplicity itself.

(Continued on following page)

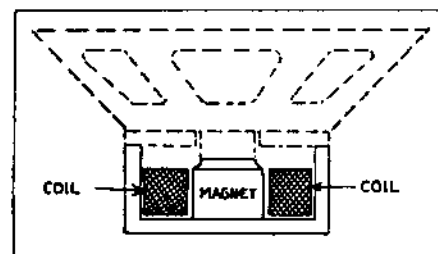
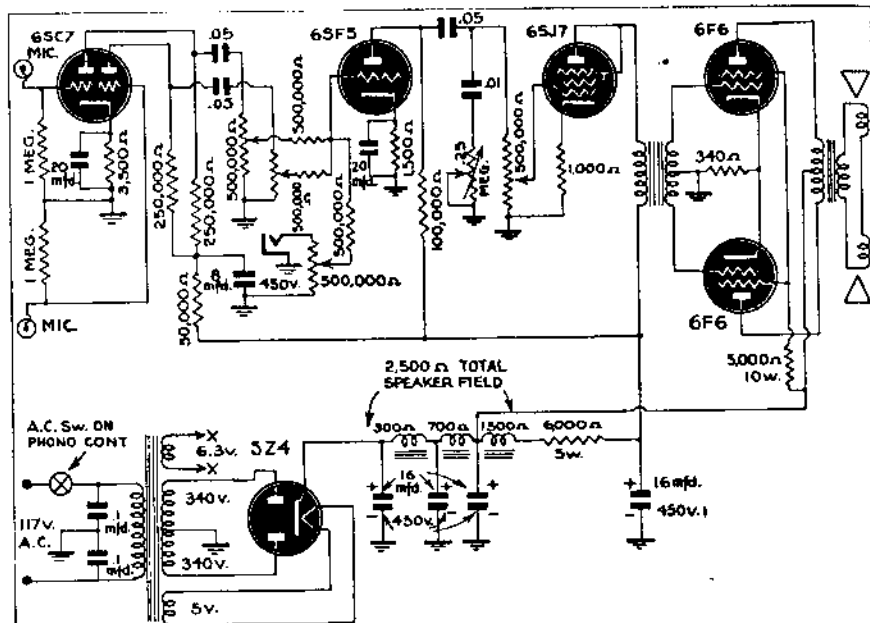

Fig. 2.—How a loudspeaker is cut down to make the magnet and coil form for the electronic guitar.



The guitar amplifier. Microphone as well as instrument pickup is provided, and the inputs can be mixed. The filter system is unusually thorough, obviating both hum and feedback. Note the two loudspeakers.

## CONSTRUCTING THE COIL

The coil is wound with the finest wire obtainable, No. 44 or better; wire obtained from the old faithful "Ford spark coil" works quite satisfactorily in a pinch. The actual size of the coil will, of course, vary slightly with the actual speaker unit used by the individual. It is a simple cylindrical coil and measures approximately 2000 ohms. It slips over the magnet "M" Fig. 1 and should fill, as completely as possible, the gap between the magnet and the field extensions.

Small angles are soldered to the pole extensions "E" (Fig. 1) so that the whole unit may be securely bolted down with rubber cushioning washers.

In order to bring the magnetic field as close as possible to the strings, an auxiliary extension "X" (Fig. 1) is made. It consists of a rectangular piece of soft iron as highly polished as possible,  $2\frac{1}{2}'' \times \frac{1}{4}'' \times 2''$ . This is cemented in place on top of the magnet proper ("M" Fig. 1) at the point "Y-Y." Its size may vary slightly as it must project through the top of the guitar far enough to come as near as possible to the strings, without touching them, even at their greatest vibration.

Thus its size or height must vary according to the height of the bridge used.

The portion marked "A" in Fig. 1, which is the original voice coil extension, is sawed off, so that only about  $\frac{1}{4}''$  of it remains. The top is filed smooth.

A special Alnico horse-shoe shaped magnet with special extensions and small high resistance coils gave no better results than the set-up shown and was much more difficult to construct. Even an ordinary head-phone with no changes made except to install a set of parallel extensions on the pole pieces worked fine.

Fig. 3 is a schematic of the hookup used for volume and tone control. Different tone control circuits may be used with equal results. Low resistance controls are essential to eliminate noise.

On completion the unit shown was given a comparative test by playing records of different artists through the phono input and mixing the guitar through one of the other inputs. This check of the tone quality as compared to that on different records proved the tone to be identical.

Moving the position of the pickup bodily nearer or farther away from the bridge, thus picking up the sound impulses at different points along the strings, produced no audible effect on the tone.

## THE AMPLIFIER AND CASE

The amplifier is a standard set-up incorporating two high gain and one phono input. It can be made simpler if desired or more complicated as regards tone circuits, etc. It may even be reduced to one input for the instrument and made of junk parts. A phase inverter may be preferred. In this rig a power of 12 to 14 watts is obtained in class AB1.

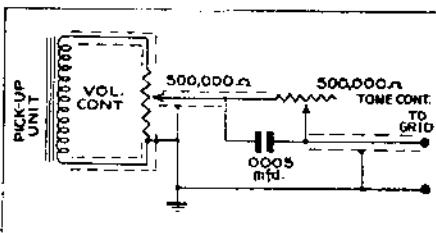

Fig. 3.—Tone and volume are adjusted by these three 500,000 ohm controls. Many musicians prefer them mounted on the instrument, which of course is quite feasible, at least with this amplifier.

It is important to mount the driver transformer as far as possible from the power transformer to eliminate inductive hum pickup. It will be noted that in the picture they are mounted right next to each other. This resulted in a vicious hum which was eliminated very satisfactorily by turning the transformer for minimum hum pickup. The line bypass condensers were also found necessary in eliminating the last bit of hum and noise.

It will be noted that the tone and gain controls are not mounted on the chassis but on the cabinet. This has worked out very well and also is O.K. from an electrical standpoint.

(Some musicians prefer the volume control on the instrument for "swell" effects. — Editor)

The cable to these controls is not shielded, and when tried it made no difference and so may be omitted.

The A.C. switch wires and tone control wire were run separately from the other side of the chassis. It is most important that two speakers be used to realize full power and tone. If you don't believe it, at least try it and you'll find yourself using two. I cannot stress too much the importance of making a pictorial diagram, messy as it may be, of where every condenser and resistor goes in order to obtain a neat, trouble-free chassis. It's a lot easier to change a diagram than a 16 gauge chassis!

The case is made of plywood and covered with a good grade leatherette, black, put on with a paper stapling machine. The speakers are mounted on a board  $\frac{1}{8}''$  smaller all around than the inside of the case so as to prevent resonant vibration of the whole box.

Experimenting showed that the manner in which the different depths and brilliance of tone are obtained is due almost solely to the musical key in which the selection

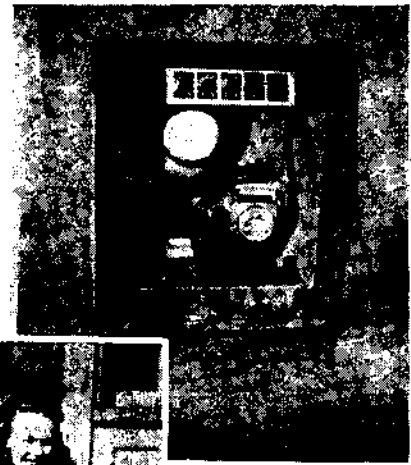

How the completed instrument (and its operator) looks. Large for a portable, its improved quality compensates for lesser mobility. The designer believes that the two speakers greatly improve reproduction.



is rendered. Proper use of the tone control merely serves to modify the effect produced. One trial is all that is required to convince even the most doubtful soul. Most music for this instrument is written in sharp keys for easy playing. When changed to any of the proper flat keys the difference is really startling.

All that is necessary to duplicate professional artists is to use the same key and tuning.

This note on the musical side is just as important as the construction notes for no matter how painstakingly and well the instrument is made it cannot be made to perform as it should unless properly used by the performer.

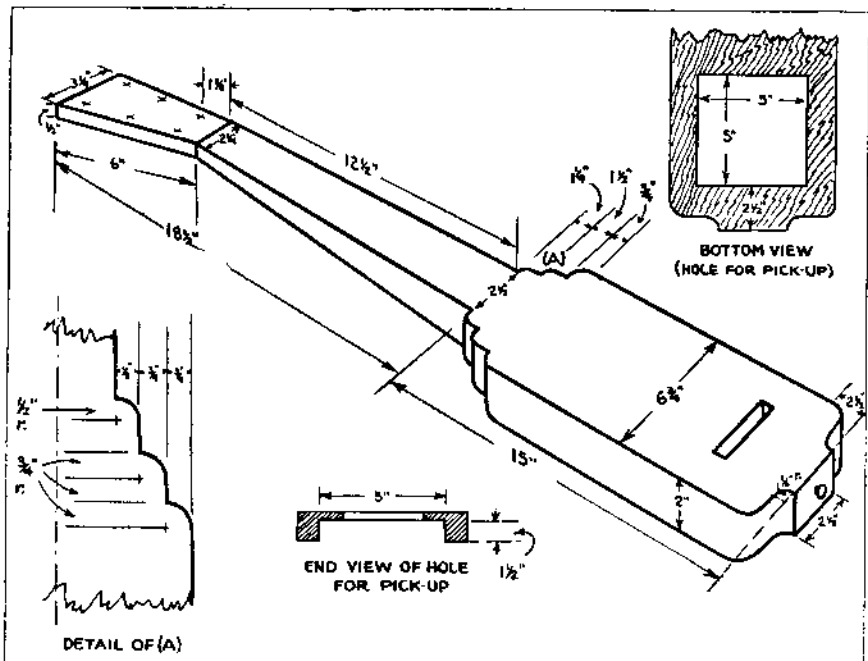

Construction of the guitar body. This should be a simple matter for any handy workman, but it is worth noting that the impression made by the instrument will depend almost as much on its appearance as sound.

# A Magnetic Recorder

## Uses Supersonic Method for Wire Recording

**A** MAGNETIC wire recorder, an electronic machine for recording voice and music on wire about the size of a human hair, is one of the post-war "wonders" that most any radio amateur or repairman can build from the spare parts laying around his shop.

The principle involved in wire recording is not new. It was invented in 1898 by Valdemar Poulsen, a Danish scientist, and since then has been improved and simplified. Wire recording has been more extensively used in Europe than in America. The machine can be used for office dictation, making oral notes in a laboratory, recording pilot's weather observations, as well as home entertainment.

The amplifier used may be any conventional circuit capable of 5 to 10 watts output with a few modifications and the addition of a low frequency oscillator. The oscillator may be on a separate chassis if necessary. The recording head, which is also the reproducer, can be constructed from old audio transformer laminations which must be filed to fit the coil being used in the head. The coil can be found in old magnetic

phonograph pick-ups or magnetic speakers.

The wire puller, the spool that winds the wire, is best powered by an old electric phonograph motor. The spools or reels on which the wire is wound can be cut out of solid wood or laminated boards. The wire guides should be of non-magnetic material such as pulleys taken from old radio dial assemblies. These components may be mounted in any number of ways to suit the individual builder.

The wire used for recording must be a steel wire with 5- to 9-tenths of one per cent carbon content. I have used piano wire .014 inch in diameter and smaller. The smaller the wire the better the quality.

I made the amplifier first. So from now on I'll discuss the building of this machine piece by piece. In the bottom of my junk box I found an old radio chassis which measures 10 by 16 by 3 inches. First I built the power supply which consisted of a power transformer capable of delivering 120 ma. at 350 volts DC. Then I built a conventional five-of-four-tubes amplifier following. The only difference in this amplifier from conventional circuits is the addition of an audio filter inserted between the pre-amplifier and the driver tube. The filter is to attenuate the low frequency signal.

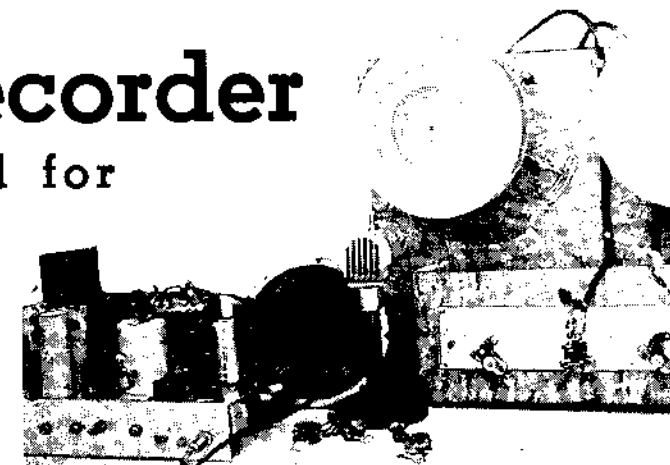

The complete set-up. Stroboscope is permanent part of the apparatus.

This filter consists of a resistance-capacity-inductance network.

The resistor is connected between the second stage coupling condenser and the driver. This consists of two 4,000 ohm resistors in series shunted with an .006 condenser, with a 125 millihenry choke connected from between the 4,000-ohm resistors to ground. Two of these are inserted in series. There is a switch between this control and ground. It is followed by a second identical network. A second coupling condenser isolates the filter from the grid of the following tube. This filter is used only when recording, the switches being opened when playing back. The setting of the controls when recording is found by experiment. If there appears to be too much bass tone in playing back it will be necessary to set the controls for less resistance in the circuit when recording.

The output of the amplifier is fed through a 0.25 mfd. condenser, C14, and a selector switch which connects to a pick-up coil on the oscillator when recording. When playing back the selector switch grounds the oscillator pick-up coil and connects the output to the voice coil of the speaker. For recording the magnetic pick-up is connected across the oscillator pick-up coil to ground. The magnetic recorder head is connected by a selector switch from the input to the output of the amplifier, depending on whether you are recording or reproducing. The complete circuit appears in Fig. 1.

The oscillator circuit is a conventional Hartley. The oscillator coil is wound on a form 3 inches in diameter and 3 3/4 inches long. The primary has 260 turns of No. 33 S.S.E. closely wound. I tapped the coil at 45 turns and then at every fifth turn up to 80 turns. The plate supply is fed into one of these taps. I found that my oscillator worked best connected to the third tap. At the terminations of the windings I used some 2-56 screws as terminals. I applied a good liberal coating of coil dope. After this dried I wound the second coil L2, or No. 1 secondary. This is the coil used in the audio circuit in recording. This coil consists of 27 turns which are also brought to two 2-56 screws as terminals. After dopping this winding and allowing it to dry I wound the second secondary, L3, which has 120 turns terminated in the same manner as the previous windings. This second secondary is the pick up coil for the erase coil, L4. Both secondaries are wound with old No. 32 enamel wire taken from an old speaker field coil. The oscillator is tuned with an .01 mica condenser and should produce a signal between 27 and 30 Kc. The action of this supersonic frequency added to the signal current is not well understood,

(Continued on page 32)



Left — Recording on the magnetic wire. Arrows show direction of wire travel.

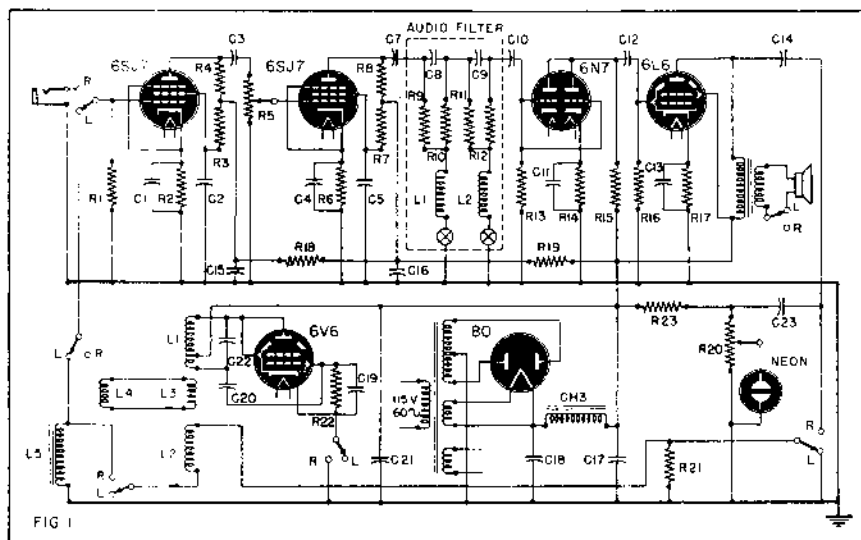



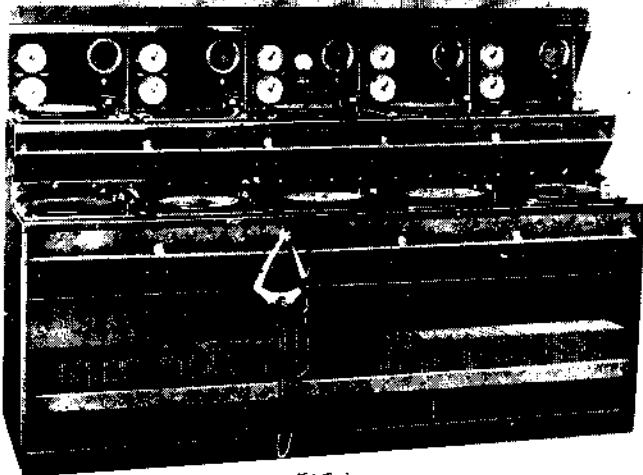

FIG. 1.

Front view of typical Central Station panel.

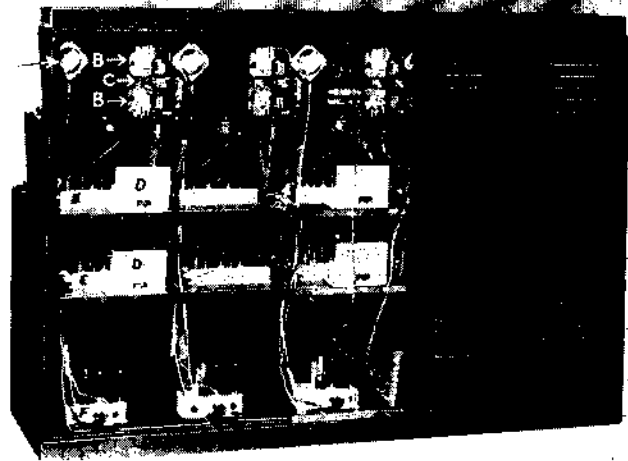

FIG. 2.

Rear of panel. Letters are explained in text.

# REMOTE JUKE BOXES

## Principles and Details of Automatic Coin Phonographs

**W**HILE the use of telephone lines for distribution of music is not new, the following article is written to clear up some of the mystery of that type of "Juke Box" where you are asked for the name of your selection and do not have to push a button.

In the first place, the building where the main equipment is located, is known as the Central Office. The place where the "Juke Box" is located is called the Remote Station. As the reader proceeds the use of the above two terms will be used to designate the two locations.

The speech equipment at the Central Office consists of: 1. The metal rack about five feet high, divided into two sections. The entire rack is known as the Board. Each Board consists of ten complete units. Each unit controls a remote station location. Fig. 1 shows a front view of the Board. On top of the Board is a wire rack, into which approximately 1000 phonograph records can be inserted. At the bottom of the Board can be seen another wire rack which holds another 1000 phonograph records. This allows the operator to have any record she may have to use at her finger tips on the instant it is asked for.

Beginning at the left in Fig. 1 are seen two dials set one above the other. Each dial is calibrated left to right from zero to twenty. These are the dials which light up and show the number of coins inserted at the Remote Station. A stepping relay is used to operate a pointer on this dial. Between the two dials and on either side can be seen the coin counting relays that record the number of coins inserted continuously. To the left of each dial can be seen push-buttons which control a buzzer to notify the operator that a coin has been inserted in case the stepping relay fails to operate. To the right is the permanent magnet monitor loud-speaker which is used to check the quality of the program and also can be used to hear what the person at the Remote Location has to say in case the operator's headset fails. Directly underneath is a tog-

gic switch which turns the power on and off for two complete units. To the right and just below the monitor speaker are two push-buttons. The top push-button connects the monitor speaker to the output of the monitor amplifier for the top turn-table and the bottom push-button connects it to the monitor amplifier for the bottom turn-table. When not in use a dummy five ohm load is cut in across each amplifier output.

There are two phonograph turntables with each section, each one being associated with a Remote Station. These turntables are powered by sturdy, variable speed motors and are equipped with an electric stop. The operator merely puts the record on the turntable platter and moves the pickup arm to the right until a click is heard. By the time she has the pickup on the record the

turntable is up to speed. These turntables require very little servicing. They are checked regularly once a week with a neon lamp and a stroboscopic disc for speed. They have no brushes and can be made to operate on 220 volts A.C. by a change in the strapping of the motor windings.

At the right and in the middle of each turntable is a triple-pole, double-throw switch. This switch is used to operate a talk-back system to the Remote Station after it has signalled the operator by means of the stepping relay or buzzer. When pulled forward, it connects a two-stage microphone pre-amplifier into the circuit. The amplifier consists of a 6SJ7 pentode, capacity-coupled to a 6J5 triode, with a volume control between the two tubes. The

(Continued on page 39)

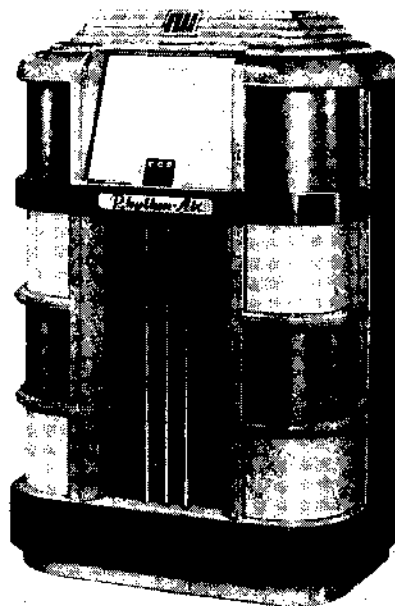

FIG. 3.

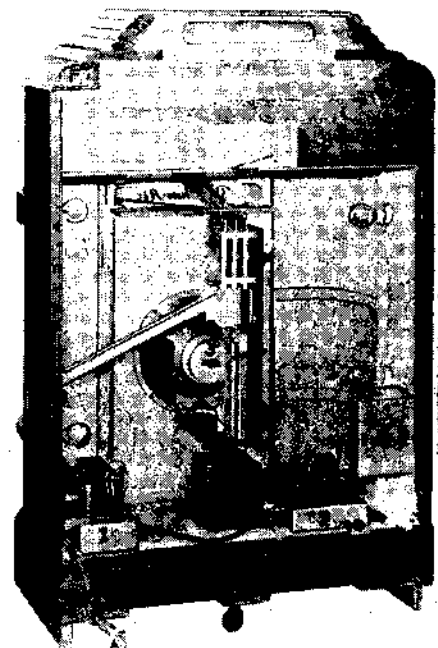

FIG. 4.

Figs. 3 and 4, right—Front and rear views of the remote station. Some special parts, described in the text, are seen in the rear view

# SIGNAL TRACER - PLUS

This Instrument Is Also A Condenser Checker And Multitester



I recently found it necessary to build my own signal tracer. As is usually the case now-a-days, parts specified were not immediately available. I did, however, have a two-stage TRF midget receiver on hand with a burnt-out 25Z5 rectifier which looked promising. From the demand for 25Z5's many such receivers must be laying around.

As I wanted more than just a signal tracer I decided to substitute a 60 Ma transformer with an 80 rectifier to provide a small power supply for other testing work I wanted to carry out. The tester as it now stands contains a signal tracer with an R.F. and A.F. pick-up as well as an A.F. output for application to any audio section of a radio under test. It also contains a Volt-Ohmmeter and a condenser tester. Some future day I expect to add a Vacuum Tube Voltmeter.

The tester is housed in a sloping front cabinet made of 1/4-inch plywood, 12 1/2 inches high, 11 inches deep and 9 inches wide. The front straight drop at the bottom is 4 inches. This allows for a sub base with the tracer under it. The front panel is made of tempered masonite 9 x 12 inches.

When the tracer is used as an A.F. generator, a tuned coil and condenser is connected to the grid of the 6K7 by means of a SPDT switch located at the back of the tester, and an aerial is connected to the aerial pin jack in the front of the receiver. The available A.F. signal can be applied to any audio tube grid or plate of the

set being tested. If the receiver's audio section is OK the signal will appear in the receiver's loud-speaker. If not, the probe can be moved from tube to tube and the trouble isolated.

## THE R.F. TUNER

In order to avoid controls the regular 2-gang tuning condenser was removed and an old oscillator padder condenser insert-

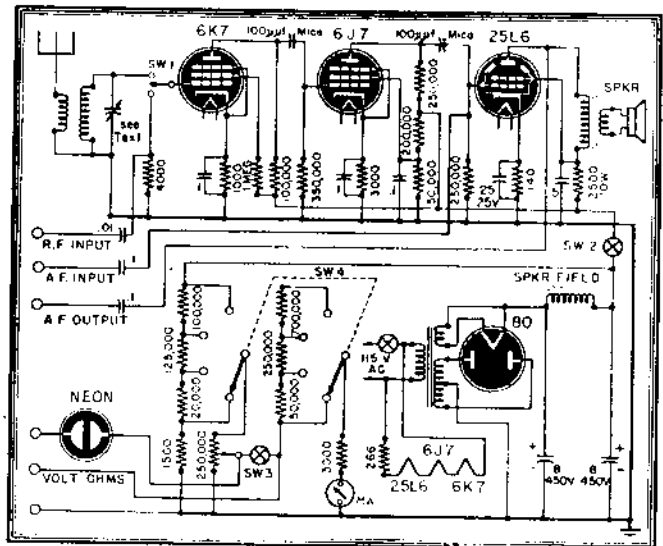

Two distinct instruments with one power supply are combined here.

ed across the secondary of a regular TRF coil. The padder was adjusted to a strong local station and once set need never be readjusted. This assures a signal at all times in the A.F. output jack, for tests on audio systems.

The untuned 6J7 is wired as a biased detector. This gives much more gain than the diode circuits mostly used for detectors. It handles the signal very well without overloading.

(Continued on page 40)

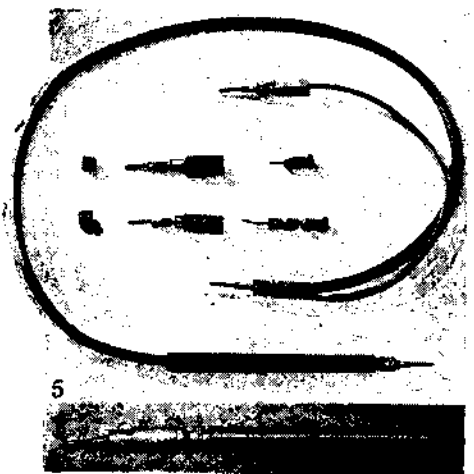
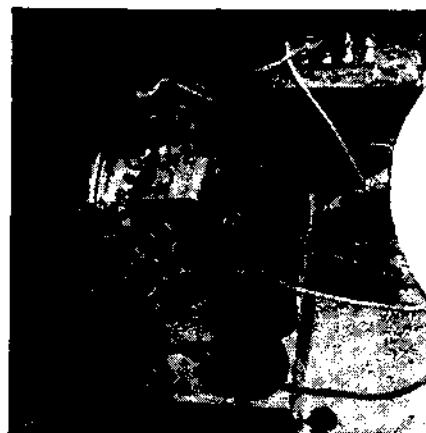

Photo 1—Rear view of the tracer and multitester. 2—Front view of the instrument. 3—Another rear view, showing neon condenser tester. 4—Under-chassis layout (one tube not used). 5 and 6—Construction of test prods.

# "STATION RIDING"

**T**HE term "Station riding" was first heard by the writer in San Francisco in 1930. It was used by radio technicians of the Bay City to describe a type of radio interference very prevalent in that area. Station riding is the type of interference that allows an unwanted signal to "ride" the carrier of a wanted signal. When a signal is tuned in on a radio receiver and station riding is present, two or more signals are heard at the same time. When the receiver is detuned, neither the desired nor the undesired signals are heard. In the case of a broad tuning or non-selective receiver, interfering signals are usually heard between stations. Station riding affects highly selective radio receivers as well as receivers with poor selectivity characteristics.

To rid the receiver of this annoying interference, many schemes were tested. Changing the antenna, a better ground connection, wave traps, etc., were tried. These methods often reduced or eliminated the interference. In other cases, the source of interference had to be located and the remedy applied at the source.

The source of station riding is usually hard to locate unless a radio interference locating device or a sensitive portable radio receiver is used. Typical causes of station riding are poor electrical contact between sheets of metal on a metal roof, two pipes touching but not making good electrical contact, antenna touching metal drain pipe, poor electrical contact at splices on guy wires attached to antenna mast or metal chimney, or almost any mass of metal making poor electrical contact to another mass of metal. (Fig. 1). The theory that has been advanced on the cause of this station riding claims that rectification of strong radio signals takes place at the point of poor electrical contact. When two or more radio signals are rectified at these points, their sum and difference frequencies are radiated by the metal objects. The more signals that are picked up and rectified, the

larger is the number of radiated beats. When several signals are rectified in this fashion, nearby receivers may pick up jumbled signals every few kilocycles on the receiver tuning range.

In one instance, the writer was called to diagnose a case where the listener complained that the radio was unusable. It was found that half a dozen mixed signals were being received every ten kilocycles throughout the broadcast band. Every carrier in-

the top piece of conduit and the switch box apparently caused rectification of radio signals. (Fig. 2.) Tightening the conduit to the box cleared the trouble.

Another case of severe station riding occurred with a popular brand multi-tube receiver which was normally quite selective. The receiver was located less than one quarter of a mile from a five-kilowatt broadcast station. This station did not cause interference, but a ten-kilowatt station fifteen miles away

rode every signal that could be tuned in on the broadcast band. The writer tried every trick in the bag including a check of the house wiring. One peculiar condition of this case was the fact that the interference ceased every day between the hours of noon and one P. M., apparently due to load

changes on nearby power lines. Since the radio was one of a very popular brand, the distributor was anxious to keep it sold, so a factory engineer was dispatched to the scene. He too tried every trick he knew including the replacement of the built-in loop antenna with an antenna transformer and an outdoor vertical rod antenna. Nothing seemed to reduce the interference, so the dealer who had sold the radio exchanged it for one of another make. This receiver worked fine without a trace of station riding. The first receiver used variable capacitor tuning and the second receiver used permeability tuning. However, this proves nothing as in other locations receivers with permeability tuning suffered from station riding just as badly as those with capacitor tuning.

**Among the most serious problems faced by the serviceman are those arising from cross-modulation, an effect produced entirely outside the set itself. A description of this type of interference and some of the means of curing it are given.**

cluding the high power local stations, was accompanied by half a dozen interfering signals. Line filters and wave traps were tried to no avail. Being a loop antenna type receiver, an outdoor antenna and ground were tried. The owner felt that it must be the fault of the radio receiver. One of another make was tried and the results were found to be just as bad.

## TRACKING DOWN THE TROUBLE

Armed with a portable receiver (which also suffered from the same interference), the writer followed the power lines in front of the house and found the interference strongest when directly under the wires. The power lines were followed to their termination in the next block at a construction company tool shack. A switch box was located on the wall of the shack. The wires were fed to the switch box through a vertical piece of conduit. From the bottom of the switch box, another short piece of conduit terminated in an outlet box. This lower piece of conduit was grounded. Upon examining the switch box, the writer slammed its door shut. The interference ceased. Moving the conduit caused the interference to reappear. Poor electrical contact between

## BY-PASSING THE LINE

Still another case. This radio receiver was one of good design with exceptionally good selectivity, but it too suffered from severe station riding. The writer found that running a short ground lead to the grounded side of the A.C. line at the out-

(Continued on page 42)

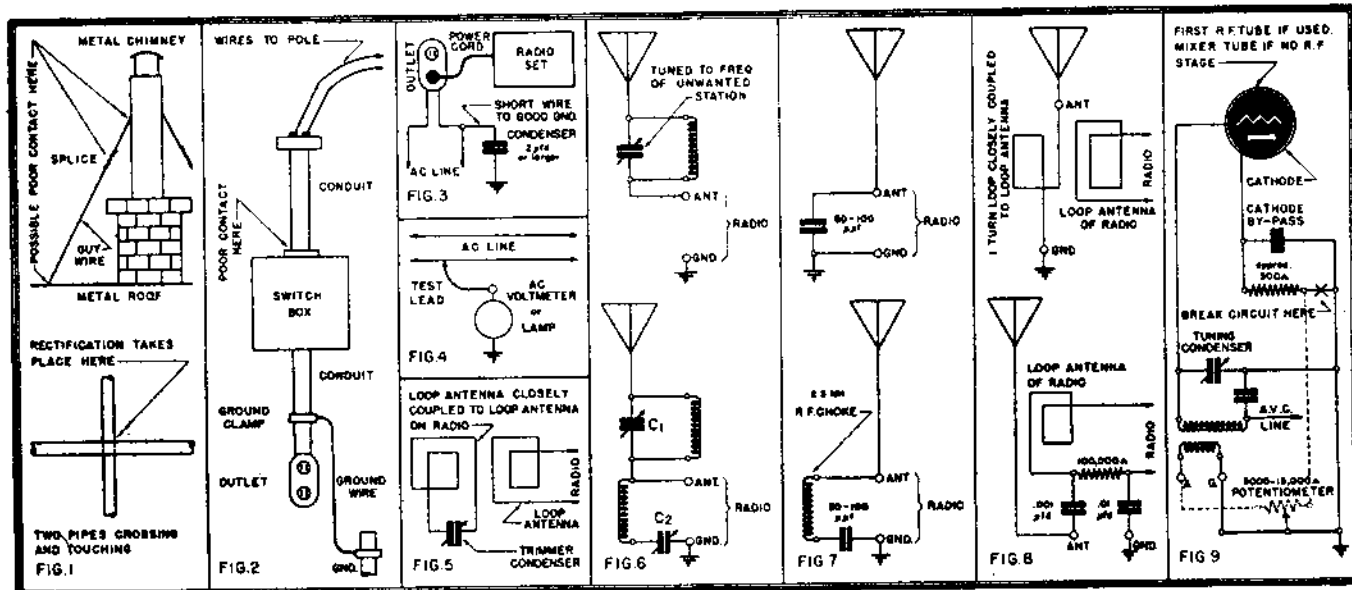

Figs. 1 to 4 show causes of station riding and their remedies; 5 to 9 how wavetrap circuits may be used. Fig. 9 is a sensitivity control.

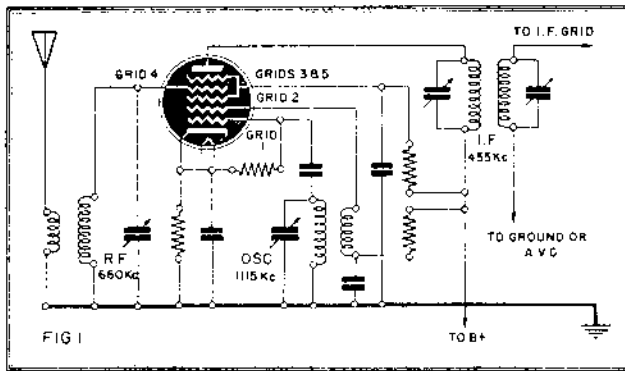

Fig. 1—Mixer stage of simple superheterodyne

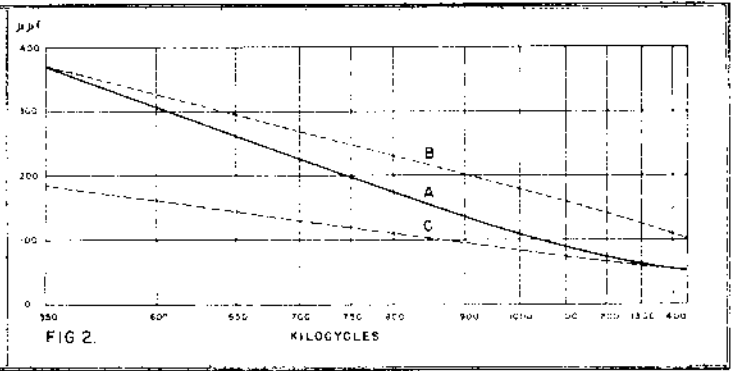

Fig. 2—First attack on the tracking problem

# HOW TO TRACK THE SUPERHET

**N**UMEROUS abandoned sets are now being modernized and put into action, often by "cannibalizing" parts from other radios; TRF's are being turned into supers; and no few constructors are "rolling their own," in some cases winding their own coils, in others taking them from old receivers.

Too many of these amateur engineers get unexpected results from their completed jobs. Some of their receivers bring in stations at one end of the dial only, others tune correctly on the high frequencies, while stations are far from their correct markings on the lower ones. The opposite trouble may be found, or all stations may be faint and crowded together in one small section of the dial. The constructors are often sorely puzzled.

The reason for their troubles is that a superheterodyne includes two distinct circuits tuned to different frequencies. These frequencies must be a definite distance apart at all points on the dial. Unless a set is carefully constructed and adjusted, this distance is not maintained—the set does not track—and such stations as are tuned in are the result of accident, when the orbits of the two circuits cross each other or come close enough to permit reception.

## MIXERS AND MIXING

In its simplest form, a super starts out with a *mixer* tube, which is really two tubes in one envelope. See Fig. 1. One section of this tube (cathode, grid 4 and plate) acts like an ordinary R.F. amplifier. The coil and condenser connected to it are tuned to the frequency of the station received. The other section (grids 1 and 2) acts like a

triode, and is connected in an oscillatory circuit tuned to a frequency usually higher by a definite number of kilocycles than the station being received. The screen-grid and plate circuits are shared by both sections of the tube. Consequently two R.F. currents flow in the plate circuit. One of these is at the frequency of the station being received, the other at the frequency of the "local" oscillator. These two are truly mixed in the plate circuit. The main result of the mixing is the appearance of a third frequency, which is equal to the arithmetical difference of the other two, and changes in strength with any variation in either of them. The signal from the oscillator section is fairly constant—that from grid 4 is modulated by the broadcast station, so the *difference frequency* (or beat frequency) is similarly modulated. An *I. F. transformer* in the plate circuit is tuned to the frequency of this modulated signal, and rejects or shorts the others.

If the difference frequency is 455 Kc. (as on many modern supers) and the I.F. transformers are tuned to that frequency, it is apparent that the oscillator must be tuned to 455 Kc. above the frequency of the station to be received. (It could be 455 below, at the cost of making tracking problems worse.) To receive a station at 600 Kc., the oscillator must be tuned to 1055 to produce the correct "beat" frequency for the sharply-tuned I.F. transformers. If the R.F. section is tuned to 650 Kc., very little of the 600-Kc. signal will get through to the control-grid of the mixer and weak or no reception will result. The R.F. must keep in step with the oscillator, and 455 Kc. below it, all across the dial, for satisfactory reception.

## WHERE THE TROUBLE LIES

These two circuits are usually tuned by one "gang condenser," so it is necessary that they be designed to "track" closely together. This is not easy. In a TRF set, all stages are tuned to the same frequency at the same time, and the only problem is to make all coils the same size. The two circuits of the super must be tuned to two *different* frequencies, and the difference between them must remain the same over the whole dial.

The difficulty is illustrated in Fig. 2. Curve A is made with a 365 (maximum) micromicrofarad variable condenser and a 230 microhenry coil. The frequency is 550 Kc. with the condenser at 365 mmf and 1450 at 50 mmf. The oscillator circuit of the set must be so designed that, at any given setting, the oscillator frequency is 455 Kc. higher than the corresponding resonant frequency of the R.F. circuit.

A capacity-inductance table shows that to tune to 550 plus 455 Kc. with a 365 mmf. condenser requires a coil of 70 mH. (Values are approximate, having been taken with a table and a slide-rule, but are accurate enough for our purposes). When the condenser is turned down to 50 mmf, the resonant frequency of this combination is 2500 Kc., not the 1905 we would like to have (See curve B, made by subtracting 455 Kc. from the curve of the 70 mH-365 mmf combination, to show how close it comes to perfect tracking.) Only one or two stations close to 550 Kc. could be received with such a combination.

The attack might be made from the other end—the high-frequency one. To tune to 1450 Kc. with 50 mmf. capacity requires a 144 mH coil. Curve C—made the same as curve B—shows how that would work out. Constructors who received only high-frequency stations on their radios will see what caused their troubles.

## HOW TO MAKE CIRCUITS TRACK

The trick is to find some means of making the oscillator tuning curve lie exactly 455 Kc. above that of the R.F. coil-condenser combination. Experience with superheterodynes has already taught us that this can be accomplished by means of semi-variable condensers. An ordinary trimmer would be of little value to us, as can be seen from curve C. To make the oscillator track at 1450 Kc. would require almost exactly 50 mmf. trimmer capacity. Should we add that capacity by screwing down the trimmer on the oscillator section of the condenser gang (supposing we had such a big trimmer) curve B would merely be lowered by 50 mmf. right across the chart. Tuning would be out by 50 mmf. at 550 instead of 1450 Kc.

There is another adjustable condenser on most superheterodynes—the padder. This is *in series* with the oscillator variable condenser. Fig. 3-a shows the arrangement. It does not always look so simple. The padder on the broadcast band is usually made up of a fixed mica condenser with a trimmer shunting it, and schematics sometimes look like Fig. 3-b. The padder is 1; the oscillator section of the gang, 2; the large trimmer across the padder, 3; and the trimmer on the gang, 4. The circuit is only

(Continued on following page)

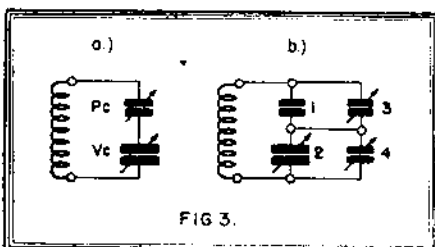

FIG. 3.

Fig. 3—Most supers use padders, which may be represented in one of the styles above.

that of Fig. 3-a with a trimmer across padder and another one across tuner.

### HOW THE PADDER WORKS

If two condensers are connected in series their joint capacity is smaller than that of the smaller one. This capacity cannot be arrived at by simple addition, but is expressed by the formula:

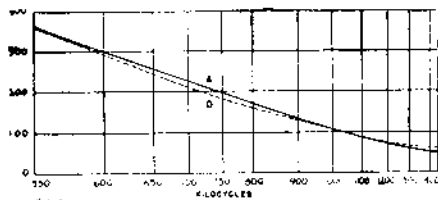

Fig. 4—Curve obtained by use of a padder

$$\frac{1}{C_1} + \frac{1}{C_2} = \frac{1}{C_{\text{resultant}}}$$

With this formula we can select a padder that will make the 144 mH coil and 365 mmf. condenser track at the low-frequency end of the band. According to the coil table, 176 mmf. is needed. Subtracting 1/365 from 1/176

$$\left( \frac{1}{C_1} - \frac{1}{C_2} = \frac{1}{C_3} \right) \text{ gives } 1/350 \text{ approxi-}$$

mately as the reciprocal of the padder size. Using a 350 mmf. padder, we get curve D (Fig. 4). A is our original R.F. tuning curve. Note that the padder throws tuning off only slightly at the high-frequency end, where it is much larger than the tuning capacity.

This is a great improvement. A set so lined up would work, though signals would be weak in the 650-850 Kc. region. It might be more effective to make the coil a little smaller, so that the two curves would coincide near the middle of the band. The padding condenser could then be made a little bigger to bring the curves together at some point near 600 Kc. and the trimmer could be adjusted to bring them together near 1400.

By varying the size of the coil, the padder and trimmer, it is possible to have the frequencies of the two coils in exactly the right relation at three points—near the top, middle and bottom of the band, and to stray very little at any intermediate point. Fig. 5 is made with a 130 mH coil and a 390 mmf. padding condenser. The tracking is almost perfect from 600 to 900. From there the two curves spread slowly apart. The trimmer can be adjusted at 1400 to bring them exactly together.

Because of the padder, a change in the trimmer capacity will not throw the tuning out as much at low-frequency points as it would in circuits without a padder. It requires about 9 mmf. to bring the two curves together at 1400 Kc. At 800, this extra capacity makes a difference of a little less than 5 mmf., and its influence rapidly disappears as the condenser is turned still further "in."

In actual practice, with two adjustments of trimmer and padder, the two curves can be kept close together practically from one end of the dial to the other.

### THE PRACTICAL METHOD

The foregoing discussion is of little help to the person who has a set which fails to track, except as it acquaints him with the reasons for his difficulties. Fortunately, it is even easier to trim up a set of coils than to read about why they need such trimming.

All that is necessary is to *free from the calibrated tuning dial all circuits but the one you are interested in at the moment.* Each circuit is thus adjusted independently of the others.

The first step is to be sure that the I.F. is correct. This requires alignment with a good signal generator. (If you have none, have a serviceman do the job.) The signal generator is also useful in adjusting the coils, but not absolutely necessary, if you can identify a number of stations in different parts of the band. All that is needed is a variable condenser of capacity approximating that of one of the sections of the gang in the set.

Mount the new condenser firmly on some part of the chassis, or if impractical, make a good connection from its frame to the chassis and put it as close to the set as convenient. Then move the coil and grid connections from the stator of the R.F. section of the gang to the new "independent variable." Now the oscillator and the oscillator alone is tuned by the calibrated dial on the set.

Set the dial at 1400 or thereabouts, and rotate the independent condenser. If the oscillator is tuned to a station it will be picked up at some position of the R.F. tuning condenser. If not, move the dial a degree or two and try again till one is tuned in. Identify the station and check its dial marking. If only slightly high or low, the oscillator coil may be the right size. If so, bring the dial to the correct point with the trimmer, then turn to a station near 600 Kc. and adjust again, as in ordinary set alignment.

### ADJUSTING THE OSCILLATOR

If the oscillator coil is too large, stations will tune in at much too high a figure on the dial—if too small, at too low a figure. Should the coil appear too large or small, it is a good idea to screw the padder down pretty well, tune in a station between 800 and 1,000 Kc., and add or take off turns till the dial reads correctly. Then tune in a station near 1400 and adjust the trimmer till the dial is correct, afterward tuning in a station near 600 Kc. and adjusting the

padder till the dial is also correct on it. Tune over the dial again, retrim and repad, possibly adding or taking off another turn or two for uniform tracking. Check again to see that all stations come in on the right dial setting.

To adjust the R.F. section, move the leads from the stator of the oscillator section of the gang to the independent condenser and put the R.F. leads back in their

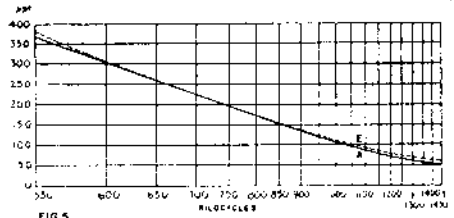

Fig. 5—Padder & Trimmer make a good curve

place. You will see now why the curves do not have to lie exactly on top of each other. The R.F. section tunes rather broadly. Turning it a degree or so off maximum signal makes little difference in the strength.

Bring in the station near 1400 with the independent condenser and note whether the R.F. circuit is nearly correct or not. If reasonably close, adjust to the exact point with the trimmer and move up to the station near 600. If it is not loudest at its proper dial setting, add or take off turns till it also tunes in at exactly the right place. Correcting the R.F. section is easy compared to getting the oscillator lined up.

Bad tracking may occur because of wrong-size padding condensers rather than coils. If the padder is too large, stations will be crowded and displaced toward the high-frequency end of the dial, only those near that end being tuned in near their correct dial markings. If too small, the displacement is in the other direction, and stations are spread apart. A larger or smaller padding condenser is the remedy, of course.

Once the reasons for its action are understood a rebuilt super is not hard to adjust. If you follow the above method you can even wind your own coils with a fair chance of success.

## New Idea In Detector Circuits

HERE is a receiver that brings in all kinds of distance with plenty of volume using but two tubes. Constructed from easily obtainable parts, I have received consistently stations within 100 miles by day and stations in Salt Lake, Denver, Portland, etc., by night, all with unbelievable volume, and sharp tuning. I use a 12 ft. indoor antenna.

The idea for this set was suggested by a patent (U. S. 2,346,545) on a new way of using a pentode tube. This showed a circuit in which the suppressor of an ordinary vacuum tube acted as a diode detector, while the tube still acted as an R.F. amplifier. I became interested in the circuit immediately, and built up and tore down several experimental models before arriving at this "final" design.

The schematic is simple. The first stage is unusual. The incoming R.F. signal coming through the first transformer, L1 (I used an iron core transformer with untuned secondary), is impressed upon the 6J7G. The amplified signal across the tuned plate circuit, L2, is impressed upon the suppressor (through a condenser).

The suppressor acts as a diode and current flows through the fixed and variable resistors, the voltage drop across the latter

being placed on the control grid to vary its average bias. The 6J7 therefore now amplifies at audio frequency, the output being across the 20 henry choke.

Coils L1 and L2 are ordinary broadcast coils of the iron-core type. The primary was removed from L2.

Note that the 2.5 mh choke prevents the passage of R.F., while the 100 mmf condenser prevents passage of A.F. The second tube acts as A.F. amplifier and power rectifier. I find it advisable to use a trimmer in the plate tuning circuit.

Because of the multiple action of the first tube, this set is really hot!

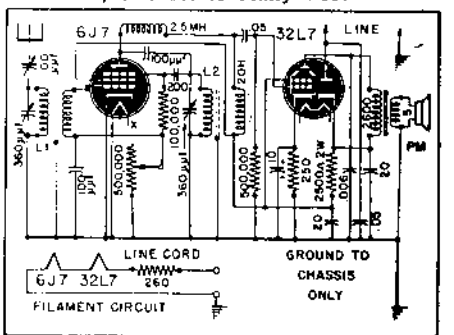

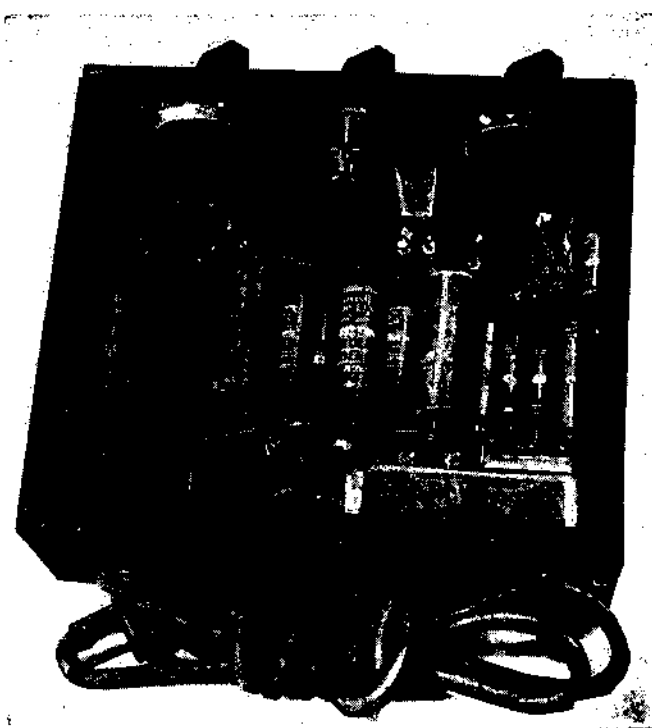
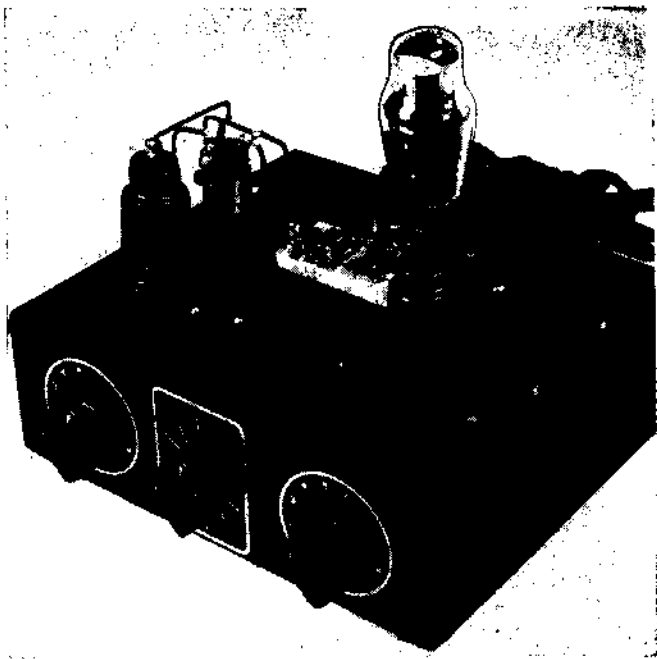

Top and under-chassis views of the Electronic Metronome.

# Electronic Metronome

**T**HIS electronic metronome will be found very handy for all students of music, especially now when it is almost impossible to buy an ordinary metronome. It works on the principle of the multivibrator, in that it distorts the wave shape to produce a multitude of harmonics.

A multivibrator is essentially a two-stage resistance-coupled audio amplifier with the second stage coupled back to the first. By varying the size of the coupling condensers

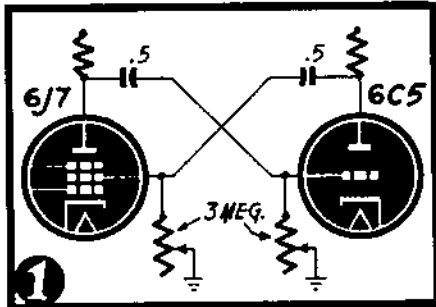

Fig. 1—Fundamental circuit of the device.

and grid resistors, oscillations—varying in frequency from the supersonic range to one or so per minute—can be produced. This instrument is so constructed that two frequency ranges are available, one in the range required for a metronome; the other suitable for a code practise oscillator.

The principle may be easily understood from Fig. 1. On the metronome range, audio output from the 6J7 is fed to the 6C5 grid. The 6C5 output is fed through a 0.5 mfd. coupling condenser back to the 6J7 grid through a condenser of equal size.

Variable 3-megohm grid resistors are provided. The frequency depends on the natural discharge rate of the resistor-condenser combinations, and if necessary can be calculated by the formula:  $1/(R_g C + R'g C')$  cycles per second.  $R_g$ ,  $C$ , and  $R'g$

and  $C'$  are the blocking condensers and grid resistors of the first and second tubes respectively.

The 6J7 is connected also as an ordinary grid-tickler type radio-frequency oscillator, with one exception. The lower end of the grid coil returns to ground through a high resistance. When, as part of the multivibrator, the 6J7 is conducting, it oscillates at a broadcast frequency, determined by  $L_1$  and  $C_1$ . Pulses of R.F. are thus sent out at the multivibrator frequency.

The coil  $L_1$ ,  $L_2$  is an ordinary broadcast antenna coil; the low-impedance aerial winding is  $L_2$ , the grid-tickler winding. If this type of coil is unobtainable, you can wind your own, on a coil form 1½ inches in diameter. Wind 90 to 110 turns of No. 28 wire on this. The grid-tickler is composed of fifteen to twenty turns of No. 30 or 32 wire. This should function satisfactorily with the two trimmer condensers in parallel, which serve as the tuning condenser,  $C_1$ , for the R.F. oscillator. No antenna is necessary, as there is sufficient radiation from this coil.

The multi-vibrator frequency range is much greater than can be obtained with a metronome. With the values shown in the schematic (Fig. 2) it is possible to obtain a beat as slow as twenty per minute. By switching in the .01 condensers, the complete audio spectrum can be covered.

When the .01 condensers are thrown in the circuit, you have a code practise oscillator that is different. A key can be inserted between the cathode and ground, and any desired tone can be obtained by varying the 3-megohm potentiometer.

Any suitable type tubes can be used in

place of the 6J7 and 6C5. A 6A7 would be particularly suitable, as you can use the plate and the No. 4 grid as the R.F. oscillator and the No. 1 grid for the multi-vibrator control. A type 76 works very nicely in conjunction with a 6A7.

Operation of the metronome is simple. Just turn it on, tune it on your radio like a wireless phono oscillator, adjust it to the desired beat, and your radio will click out the rhythm while you proceed with your musical practice. One precaution: Be sure that you are not radiating such a strong signal that you are creating interference. The F.C.C. has established a definite ruling on that matter. *There must be absolutely no interference with other radio reception.* This is absolute. Should a neighbor in an adjoining apartment—say 30 feet away—hear your metronome or code oscillator while listening to a local station, your machine is clearly illegal.

A simple formula for determining if your "transmitter" is illegal or not is:

$$157,000 \text{ ft.}$$

frequency (Kc.)

For example: if a device is operating at 550 Kc., the permissible range is 157,000/550 or approximately 285 feet.

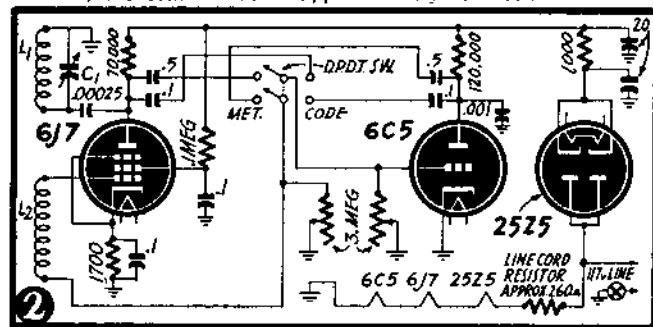

The metronome is adjustable for wide frequency variations.

# ECONOMY 20-WATTER

**T**HIS amplifier was originally designed and built a couple of years ago, partly to maintain the writer's reputation and show up some of the very inferior jobs used in dance-bands, etc., and partly to see how much power could be got from how small an amplifier.

The tube line-up is: 6SC7 as first voltage amplifier for both crystal microphone and needle-armature hi-fi pick-up, 6SC7 as driver and phase inverter, a pair of 6N6G's in class AB<sub>1</sub>, with the load reduced from 10,000 ohms to 9000 and the bias resistor increased to 325 ohms. In addition, a 300 ohm resistor of 5-watt rating must be connected in series in the high voltage supply. However, the 6N6G or 6B5 tubes should be used if possible as these give superior tonal quality besides being very noncritical as regards load impedance (a 100% rise in load impedance causes less than 5% rise in power output).

The power supply is very economical indeed, as the transformer has a rating of only 100 Ma. This is quite enough as the total no-signal drain is only 92 Ma. for the whole amplifier and the average drains on speech and music are only 95 and 98 Ma. respectively, although peak drains of about 110 Ma. may be encountered for periods of about a tenth of a second.

## PHASE INVERTER

The phase inverter uses the floating paraphase system, this giving an automatic near-balance, the "second" output tube receiving slightly less drive than the first. Inverse feedback is applied from the primary of the output transformer to the plate of the driver (first section of the second 6SC7). This feedback gives a reduction in distortion, a reduction in hum and also a reduction in the unbalance of the output tubes. The reduction in unbalance occurs in two ways—first the general negative feedback action reducing the drive more in one direction than the other, secondly the bias resistor of the phase inverter is not by-passed so that the first section (working at a higher level than the other, because of the feedback gain reduction) drives the second section, thereby increasing its output.

Between the phono pick-up input and the grid of the first 6SC7 is a resistance capacity network giving a bass boost of approximately 8 db at 100 cycles and 13 db at 50 cycles to compensate for the attenuation of bass in the ordinary lateral recording. The network has an impedance of approximately 30,000 ohms at mid-frequencies, that being the load required for the pick-up employed. Should an ordinary crystal pick-up be employed, then the large condenser in the network must be shorted and each resistance increased in value 20 times. For an ordinary magnetic pick-up, the network can be left as it is for a pronounced bass, or the large condenser can be bridged by a 3000 ohm resistor for a more normal approach to bass reproduction.

It may be wondered why electronic mixing is not used as there is a triode section for each input. This would mean, however, the placing of each volume control right at the input—a quite sound arrangement only if each control is quite free from noise and can be completely shielded. The writer has found in practice that the conventional parallel mixer circuit shown is much better. Theoretically the movement

cut filter is connected across the output. A variation in capacity is used in place of a fixed capacity and variable resistance, as the lack of a resistance gives a sharper cut-off. The filter is placed at the output for the same reason, the rise in impedance of the speaker at the higher frequencies producing a sharper cut-off. It should be noted that this tone control is not so much to control tonal balance as to permit more pleasant reproduction. If a wider range of control is required, more points could be fitted and larger condensers used on the switch. As the voltage between each output anode and the chassis consists of the high voltage (400 volts) together with the peak value of the output signal (about

320 volts), any condenser connected between the output anode and chassis is liable to breakdown. Greater reliability is obtained by connecting 600-volt condensers in series as shown so that there are always at least two condensers in circuit, giving a minimum working voltage of 1200, an ample safety rating.

To handle the 20 watts output without excessive weight a model TX Amplion speaker transformer is used. Alternative types are available in the Rola range and no doubt American enthusiasts can find dozens of suitable brands. The transformer is mounted on the chassis so that there is no high voltage between the speaker leads, which are run at voice-coil impedance (12.5 ohms in this case). There are two 12.5 ohm outlets (connection is made by UX sockets at the back of the chassis) so the output transformer is wound with a 6.25-ohm secondary. A pair of terminals on the front of the chassis go to this 6.25 ohms winding so that leads can be run to a booster amplifier or to a pair of public address horns, should the constructor so desire.

The speakers normally used are a couple of 12P64 Amplions, each being capable of handling the 20 watts output by itself. Alternatively a single Rola G12 permag. can be connected to the terminals on the

(Continued on page 32)

**High fidelity and plenty of output with a minimum of tubes and components are obtainable with this circuit, which increases its output by using direct-coupled dual amplifier tubes.**

of the microphone volume control should slightly change the volume from the pick-up and vice versa, but in practice the change is negligible, and is reduced still further in this amplifier by the tone-compensation resistors connected between the moving contact and grounded end of each volume control. These resistors reduce the bass response at full output to make up for the ear being relatively more sensitive to the lower frequencies at high volume levels and to prevent overload of the speaker. It is not commonly realized that the power handling capacity of a speaker is restricted in the low frequency region. A speaker capable of handling 30 watts at 400 cycles may be able to handle only 5 watts at 30 cycles, providing it has the same efficiency at the lower frequency. Nothing is more distasteful than the banging of a speaker diaphragm on the low-frequency peaks—generally the freer the suspension and the lower the resonant frequency, the more liable is the diaphragm excursion to be excessive.

## THE TONE CONTROL

In order that worn records may not sound too bad and to eliminate some of the harshness from overpowering vocalists who hug the microphone, a simple high-

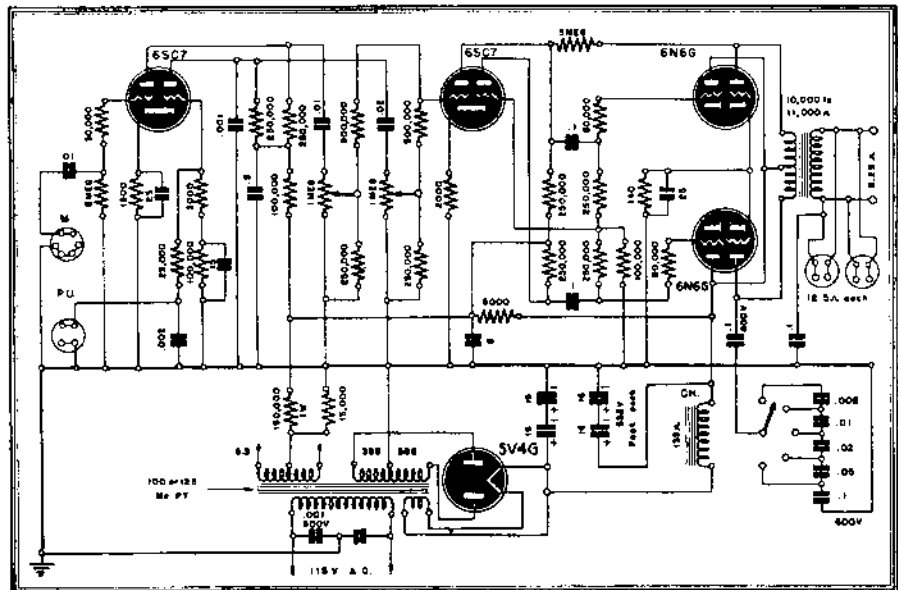

The 6N6 output stage is actually two cascaded stages. A self-balancing inverter is employed.

# CAPACITESTER

This instrument will test a condenser in position, without disconnecting its leads, and will also show up intermittent opens. A "must" instrument for radiomen.

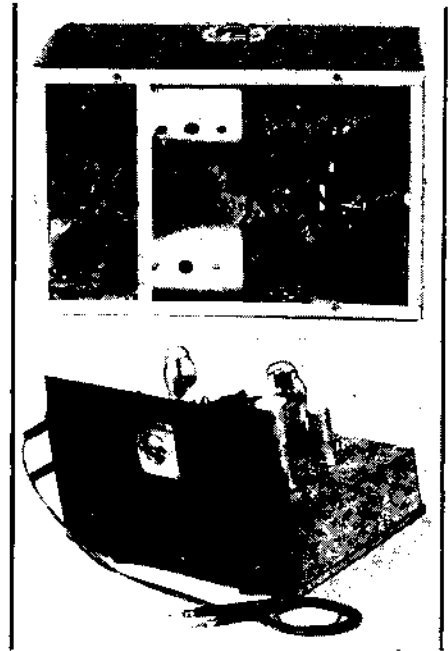

Front and under-chassis views of the capacitester, used for dynamic checks on condensers

**T**HE condenser quality tester described in this article is the result of considerable experiment and design and it has the following advantages: (1) Checks the quality of the condenser while connected in the circuit. (2) Positive indication with no charts or figuring. (3) Ease of operation using ordinary test prods, no shielded wires or awkward terminal connections. (4) Provision to test resistance or voltage across the condenser simultaneously with the quality test. (5) A locking circuit which could be used in cases where the tester had to remain across a suspected condenser for a period of time and would give a positive indication without the necessity of the operator constantly watching the indicator. (6) Low cost, easy construction and economical operation.

## CHOICE OF CIRCUIT

The circuit decided upon consists of a 76 oscillator, link coupled to a tuned circuit, both operating at eighteen hundred kilo-

cycles of a 6E5 tuning indicator tube.

Since the link circuit is carrying radio frequency at low potential, any resistance or reactance in series with it will lower the energy transfer from the oscillator to the tuned circuit. The frequency chosen, 1800 kilocycles, will encounter a reactance of approximately 10 ohms when applied in series with a .01 mfd. condenser. Most condensers used in radios and associated circuits have capacities greater than this. It follows that their reactance will be less. Since the values of resistances used in radios are generally 200 ohms or greater, if a .01 mfd. condenser is placed across a 200 ohm resistor and this combination tested by this instrument, taking the energy transfer to represent 100 per cent, it will be found that 95 per cent passes through the condenser and only five per cent through the resistor. Therefore if the condenser should open circuit there will be a loss of 95 per cent of the energy transfer in the link circuit.

In a case where the resistance is devel-

oped internally in the condenser (contact resistance as it is generally called) the energy transference loss will be governed by the voltage drop across this resistance. It can readily be seen that the resistance or reactance connected across the condenser

is so much higher than the reactance of the condenser itself, that it may for all practical purposes be disregarded. Any internal resistance or contact resistance in the condenser itself will reduce the energy transfer in direct proportion to the amount of resistance developed.

The locking part of the circuit is as follows. The negative bias used to close the 6E5 tube's shadow is also applied to the grid of a 6F5 used as the locking tube. Its plate is connected through a toggle switch to one side of the secondary of a three to one ratio, audio transformer. The primary of the transformer is connected to the A.C. line connections across the regular power transformer. The ground return of the secondary goes through a 500,000 ohm resistor. It takes approximately eight volts negative bias to completely close the shadow on the 6E5 magic eye tube and this same voltage is applied to the grid of the 6F5. Due to the tube's high mutual conductance it is biased to plate current cutoff. However, if there is any failure of the energy transfer link circuit caused by the condenser under test opening or the circuit being opened in any way, there is no longer any radio frequency flowing through the circuit. The result is with no radio frequency to amplify and rectify in the tuned circuit, the grid bias falls to zero potential on both the indicator and locking tube grids, the indicator tube's shadow opens wide and the locking tube passes plate current the negative component of which is applied to the grid of the 6B7 pentode section stopping it from amplifying any further even if the energy transfer link circuit should be closed again. Therefore the indicator tube's shadow remains locked open until the switch in the plate circuit of the 6F5 tube is opened, allowing the other circuits to operate normally again.

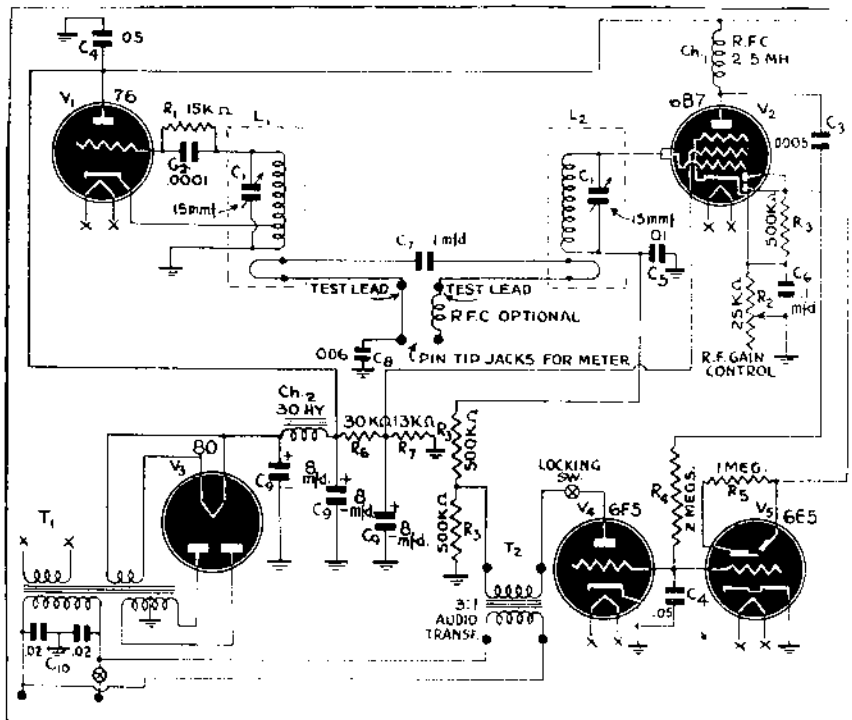

cycles. The link circuit is broken on one side and brought out to pin tip jacks. The tuned circuit is connected to a 6B7 pentode section. The output of the pentode section is rectified in the diode section and the negative potential developed is applied to

opened internally in the condenser (contact resistance as it is generally called) the energy transference loss will be governed by the voltage drop across this resistance. It can readily be seen that the resistance or reactance connected across the condenser

## CONSTRUCTING THE CHECKER

A chassis nine by twelve inches was used. A panel twelve by eight inches is mounted on one side with the indicator tube located in the upper center, the gain control and

(Continued on page 34)



# Matching Loudspeakers

## How to Attach Unlike Speakers to One Output Transformer

**T**HE technique of speaker matching is well understood by every radio-man—up to a certain point. When two speakers of unequal impedance are to be attached to the same amplifier, this understanding is not so general. And if the speakers are of unequal wattage rating as well as voice-coil impedance—each one to receive its correct proportion of the total power—few radio servicemen indeed can toss off an answer to the problem. More than one compromise installation is the result of their inability to do so.

As a simple example: We need to connect a pair of 5-watt speakers with 16-ohm voice coils and one 20-watt speaker with an 8-ohm voice coil to a 30-watt amplifier. How are we going to hook up the speakers so that the power will be properly distributed? Remember that the speakers have to be connected across the secondary of a universal output transformer, and the speaker load must be properly matched to that required by the tubes.

The problem is not too difficult. One of the reasons so many radiomen are stumped by it is that they have learned too much about matching. They cannot imagine attaching an 8-ohm voice coil to anything but an 8-ohm tap. If it becomes necessary to hook a monitoring speaker across the 500-ohm line, they do it with dark forebodings as to what might happen at the other end. It is necessary to forget all that. If we are going to connect several speakers to the same winding, obviously we cannot proceed as if we had only one, and that means we can't "match" tap and speaker ohm and ohm.

### TRANSFORMER CALCULATIONS

The chief reason for an output transformer is to match the impedance of the output tubes' plate circuit (usually between 2,000 and 10,000 ohms) to that of the speakers' voice coils (commonly between 2 and 16 ohms). If the voice-coil impedance is 6 ohms and that required by the output plate circuit—for best results—is 6,000 ohms, the impedance ratio is 1,000 to 1. The voltage ratio is the square root of the impedance ratio, or in mathematical terms:

$$\sqrt{Z_p/Z_s} = E_p/E_s$$

Our specimen transformer then has a voltage step-down of  $\sqrt{1,000}$ , or about 31.5. It is likely to have about 2,000 to 3,000 turns of wire on its primary and from 60 to 30 turns on its secondary.

The impedances of a universal output transformer are usually marked, but the turns or voltage ratios are not. Our only interest in these voltage ratios is that they help us to understand some of the electrical actions of the transformer, and thereby to figure out which of the secondary terminals we have to attach our speakers to.

To get the underlying principles straight let us try the simplest possible hookup (Fig. 1). The whole 30 watts is being fed into one 8-ohm speaker. Voltage across the 8-ohm voice-coil winding is 15.5 rough-

$$W = \frac{E^2}{R}, \text{ or } 30 = \frac{E^2}{8}$$

1.94. The impedance ratio,  $Z_p/Z_s$ , is 6,000/8 and the voltage ratio is the square root of that, about 27.4. The primary voltage is  $15.5 \times 27.4 = 425$  approximately. This can

be checked by calculating direct from the primary watts ( $30 = \frac{E^2}{6,000}$ ).

Now we can try a hookup like that of Fig. 2, which has two secondaries. We connect the two 16-ohm speakers in parallel, making an 8-ohm unit to place across one secondary. The 20-watt speaker, also an 8-ohm unit, goes across the other. What should be the impedance of the primaries?

First, 10 watts must be fed to the two-speaker unit. Using our formula,  $10 = \frac{E^2}{8}$

or  $80 = E^2$ , the voltage across the voice coil works out to slightly less than 9. To get the voltage ratio, we divide 425 by 9, which is 47.2. Since  $Z_p/Z_s = (E_p/E_s)^2$ , we square 47.2, giving us 2,228. The impedance is 6,000/2,228, or roughly 2.68, which should be the rated impedance of a winding to supply the two small speakers.

The single speaker is to draw 20 watts. The same calculation makes the voltage

$$\text{about } 12.65. \left(20 = \frac{E^2}{8} \text{ or } 160 = E^2\right)$$

Dividing that into 425, the turns (voltage) ratio is near 33.6. Squaring this, we get 1128. The impedance of the secondary coil is 6,000/1128, or roughly 5.32 ohms.

(All the foregoing figures are obtained from the slide-rule, and are approximations, but are more than accurate enough for this work.)

Since the secondary impedances are effectively in parallel, two separate windings are unnecessary. It is easier to hook each speaker to the proper impedance tap on a universal speaker, as in Fig. 3. This is what is done in actual practice.

### THE REFLECTED IMPEDANCE

Now, are these impedances correct? On the surface, it would not seem so. One 8-ohm winding is attached to a tap whose impedance is slightly less than 3 ohms—the other to one of a little over 5 ohms impedance. Let us see if anything like 6,000 ohms is reflected back into the primary. If so, the speakers are matched to the output tubes.

The impedance reflected into any primary winding is due to the resistance of the secondary winding load and the transformer ratio. An 8-ohm load across an 8-ohm tap reflects the rated impedance (6,000 ohms) back into the primary. Placing the same load across a 4-ohm tap would reflect 12,000 ohms or 8/4 the normal impedance.

One of our windings will therefore reflect  $8/2.68 \times 6,000 = 17,900$  ohms and the other  $8/5.32 \times 6,000 = 9,060$  ohms. Adding the two parallel impedances, we get  $1/17,900 + 1/9,060 = 1/6,000$ . The impedance reflected into the primary is 6,000 ohms. The speakers are effectively matched to the amplifier.

In many cases the required impedance taps are not found on the output transformer. Connect to the nearest tap, checking the effect on power distribution and so averaging the mismatch of individual taps that the total reflected impedance will be as nearly correct as possible. If it is necessary to err in either direction, con-

nection should be made to taps of slightly lower than correct impedance. Thus the reflected impedance will be a little high. This will merely reduce the power slightly,

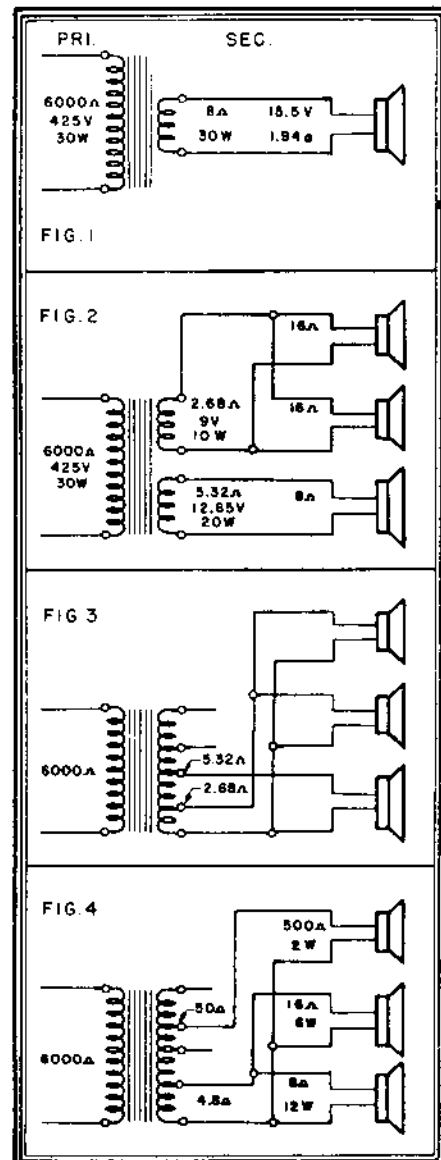

Fig. 1—Simplest speaker matching problem.  
Fig. 2—How three speakers could be matched.  
Fig. 3—All three on one output transformer.  
Fig. 4—Matching widely different speakers.

whereas too low an impedance facing the output tubes would harm fidelity.

Speakers may also be matched by their output transformer primaries. Thus two 12,000-ohm primaries could be connected in parallel across the 6,000-ohm impedance of the output tube(s). This method is useful where speakers are some distance from the amplifier.

A quicker method of calculating the correct taps can be worked out from the example just given. Each speaker in Fig. 3 was so mismatched to its transformer winding that it got its own share of the power, yet all speakers when paralleled

(Continued on page 38)

# MEASUREMENT OF CAPACITY

UNTIL very recently the subject of capacitance measurement has been rather neglected in radio publications, condenser testers usually taking the form of leakage or short indicators only. With commercial apparatus capable of measuring capacitance off the civilian market for some time, technical information on this subject is important to the serviceman and technician.

This article is concerned with methods whereby capacitance may be indicated on

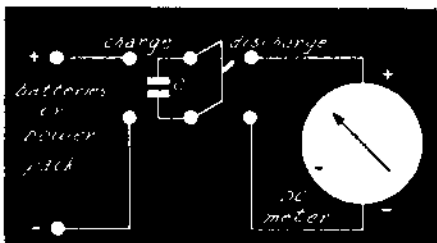

Fig. 1—Hook-up for "ballistic" measurements

an A.C. or D.C. milliammeter or A.C. voltmeter. Either the meter face may be directly calibrated or the indication may be made to coincide with a prepared chart. Properly designed meters of the types to be described may be relied upon to within 2% accuracy, and the measurement may be quickly made so that a good deal of time is saved. Three general methods will be discussed, each requiring a different type of meter generally available to the radio man.

## THE BALLISTIC METHOD

This method is often used in the laboratory for measurement of capacitance of transmission lines. Fig. 1 shows the set-up. First we charge the unknown condenser to a definite voltage  $E$  (direct current) which may be of any value less than the breakdown voltage of the condenser. If we use the maximum voltage permissible with the given condenser we automatically check for breakdown, also.

After a second or so, the switch is

Cap.	Voltage	Microamp
16 mfd.	1.5	300
	3.0	600
	4.5	900
30 mfd.	1.5	520
	3.0	1040
1 mfd.	1.5	15
	3.0	30
	4.5	45
.1 mfd.	10	6
	20	12
	45	28
	90	56
	135	84
.05 mfd.	180	112
	90	29
	135	43
	180	56

Fig. 2—Table of currents for a given meter

thrown to "discharge," and the total quantity of electricity on the plates now passes through the D.C. microammeter (or milliammeter). The meter kicks upwards to some value and then returns to zero.

This method is often used with a "ballistic" or weighted movement type of meter. Strictly speaking, only the ballistic type will actually measure the total quantity of electricity in the condenser, because the total effect of every electron passing through has a bearing on the final indication. In other words, the condenser is fully discharged before the maximum swing is reached.

This type of measurement can, however, be used very successfully with an ordinary D.C. microammeter or milliammeter. A low leakage toggle switch (possibly the spring-action type which snaps up when released) can be used to good advantage here.

The accompanying table (Fig. 2) shows what to expect from this method. An ordinary Triplett type microammeter (with proper shunts) was used in obtaining these results. Note that larger deflections are obtained when using higher capacitances or higher voltages. Note especially the excellent LINEARITY which may be obtained with different voltages. This means that only a few values need be calibrated, and all others obtained by drawing a chart on linear squared paper. The graph will be a STRAIGHT LINE, so that it is possible to use whatever source of direct current is available.

While this linearity results with a change of voltage, note that a change of capacitance is not quite linear, although very nearly so. With a sensitive microammeter, a condenser of .005 mf. may be measured conveniently with a voltage of about 90. High capacitance condensers offer no problem and may be accurately indicated with very low voltages as shown. This is especially interesting in the case of low-voltage high-capacitance electrolytic filters upon which only a few volts may safely be impressed.

Since the condenser charges to the open-circuit voltage of the applied source within a short time, a new battery does not have to be used, nor is a voltmeter an absolute necessity, unless the highest order of precision is required.

Due to the fact that one quick swing of the pointer takes place, after which it settles back to zero, it is essential that the maximum indication be accurately noted when high precision is needed. For this purpose an optical shield may be used. This merely consists of a card

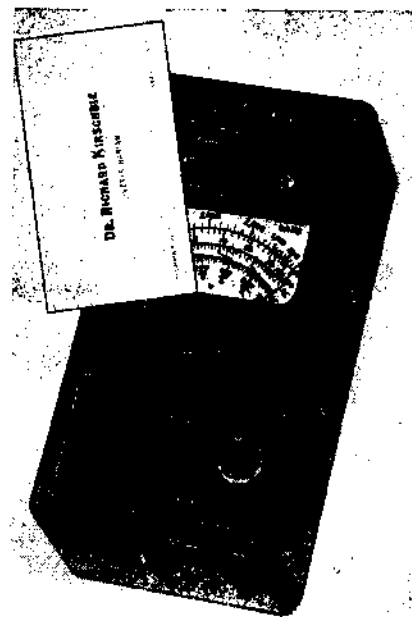

Fig. 3—An optical shield used for accuracy.

which is used to cover part of the scale, as in Fig. 3. When we find a position such that the needle is just visible during a measurement, the card is evidently pointing to the maximum reading and therefore corresponds to the desired result. Several tries may be necessary if extreme accuracy is required.

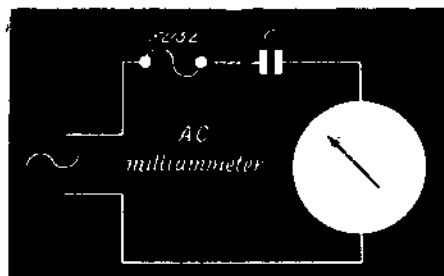

Fig. 4—A.C. milliammeter as capacity meter.

It may be pointed out here that the ballistic method is based upon the formula  $Q = C \times E$ , where the units are coulombs, farads, volts. A properly-designed "ballistic" meter reads in terms of coulombs or millicoulombs and would therefore be linear throughout the range.

This type of measurement actually indicates several characteristics of the condenser under test: capacitance, by maxi-

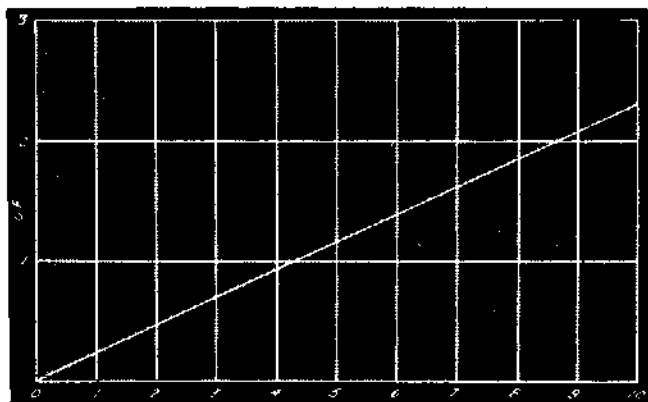

Fig. 5—Milliampere-microfarad chart, used with circuit of Fig. 4

num swing; breakdown, by no reading (with no danger to the meter itself); leakage, by a much lower reading when the condenser is left to stand for a short while between "charge" and "discharge."

By observing polarity, electrolytics may conveniently be measured in this manner.

### A.C. MILLIAMETER METHOD

The circuit is shown in Fig. 4. The unknown condenser is connected in series with the meter and a known source of alternating current, for instance the line. It is wise to fuse the circuit. Lower readings correspond to lower capacitances. The face of the meter may be calibrated in capacitance units for direct reading or reference may be made to a chart as in Fig. 5.

The chart shown is applicable to 115 volts, 60 cycles. (For any other frequency—such as 50 cycles—we may read off the chart as before and multiply the result by 60

—, etc.) Other voltages of the same frequency give proportionate indications. For example, 11.5 volts, 60 cycles, would give a reading only 1/10th as large as would 115 volts, for the same condenser.

While the chart shows readings only from 1 to 10 milliamperes, extension to lower or higher ranges is easily accomplished. If the indication is 25 ma., the condenser being measured is 10 times as large as is indicated for 2.5 ma., and so on. The same holds for lower readings, .25 ma. indicating a condenser one-tenth as large.

This method is based upon the fact that the capacitive reactance of a condenser is given by  $X_c = \frac{E}{2\pi f C}$  (C in microfarads),

and that  $I = \frac{E}{X_c}$ , disregarding fuse and meter resistances. This gives  $I = \frac{E \cdot 377 C}{10^3}$

(I in ma.). When  $E = 115$  volts  $C = \frac{I \cdot 110^3}{4336}$

This may be simplified to  $C$  (mf.) =  $\frac{I \text{ (ma.)}}{4.336}$

### A.C. VOLTMETER METHOD

This method is illustrated in Fig. 6. It requires no fusing, since the voltmeter is first adjusted so that it reads full-scale when the terminals are shorted. Short-circuit is then equivalent to infinite capacitance. As in the two previous methods,

larger capacitances show greater deflections of the meter used as an indicator.

Another typical capacitance-measuring meter is the Weston 664, circuit of which is shown in Fig. 7. This is a more elaborate unit, having five ranges for capacitance: "÷1000," "÷100," "÷10," "C," "C × 10" (besides other ranges for A. C. volts). The face is calibrated from 0 to 20 mfd., so that readings may be obtained from .0001 to 200 mfd.

The basic A.C. meter used in the Weston 664 has a full scale of 2 1/2 ma. The multiplying ranges are obtained by suitably shunting the meter so that it reads higher values at the higher ranges. At "C × 10" the meter reads 100 ma. full scale. For the higher reading scales the impressed voltage is reduced. For the lowest scale it is almost 100 volts, while for the highest it is but 4 volts, a small transformer being used for the stepdown. Isolation of the line voltage is used on all ranges and is a desirable feature.

Assuming that we now have an A.C. voltmeter arranged to read full-scale with no condenser in series with it (Fig. 6), let us discuss means for designing multiplying factors. For convenience, these factors may be 10, 100, etc.

Looking at Fig.

8-a, we may note that a definite reading will be obtained when the unknown C is placed in series with the voltmeter. Now we shunt the meter itself with  $R_m$  equal to 1/9 the meter resistance and add a series resistor  $R_s$  sufficient to cause the meter to read full-scale when XX is shorted. The scale is now a "× 10" scale, all indications being ten times as large as previously. Notice that ten times the current is now flowing in the circuit.

Another multiplying method involves a decrease in the voltage source (Fig. 8-c and 8-d). To multiply all indications by 10 it is necessary to reduce the voltage source to one-tenth. The series resistor R is then reduced until we again obtain full-scale reading when XX is shorted. In both

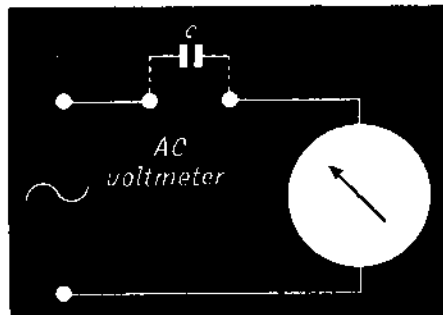

Fig. 6—Measurement with an A.C. voltmeter.

methods the multiplying range shows a total circuit resistance one-tenth the original range.

Instruments for all the above measuring methods are easily set up and require only a meter of a type usually available. The would-be constructor can adapt any one of several types to one or another of the circuits given above. Only a little ingenuity is required to construct a combination instrument capable of measuring capacitances over an extended range, and such instruments can be built up with either an A.C. or D.C. foundation meter.

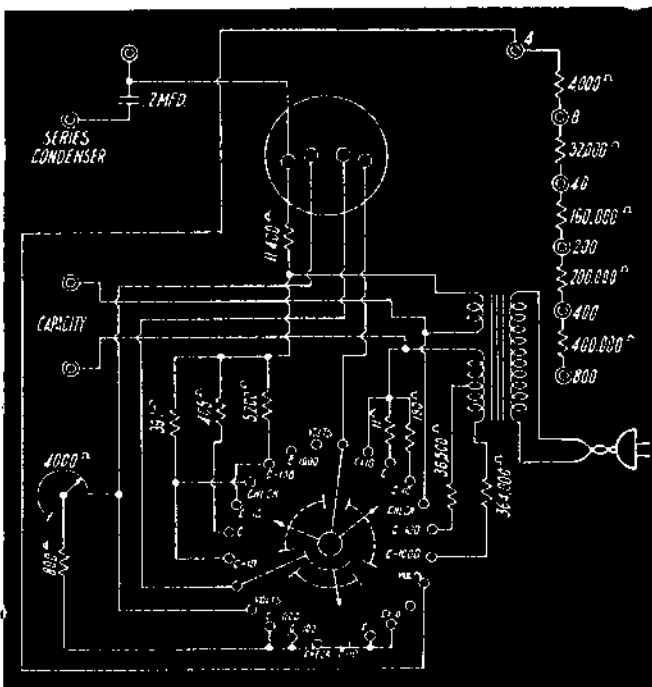

Fig. 7—The Weston 664, a wide-range commercial capacitance meter.

The designer will find almost as much use for such a unit as for his ohmmeter.

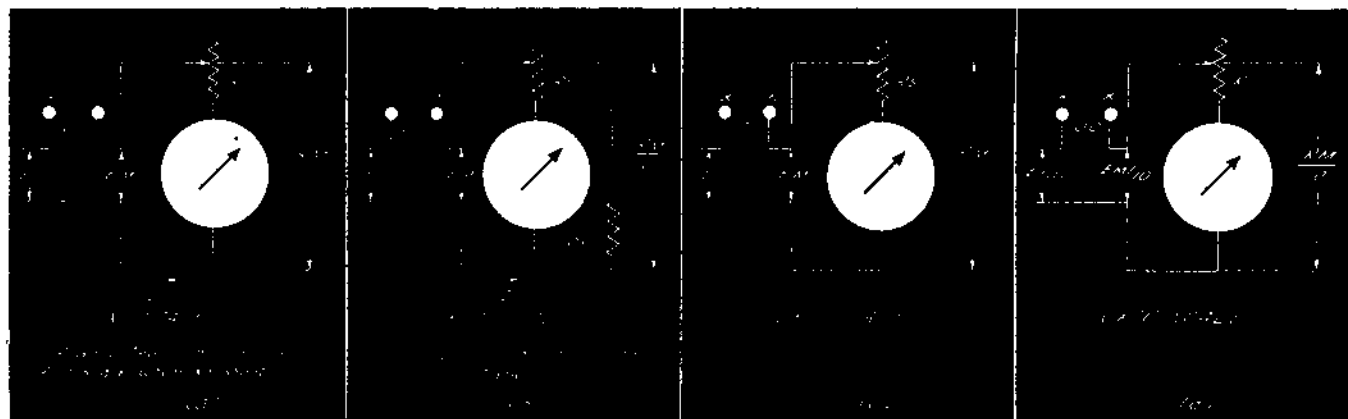

Fig. 8—A Single meter may be used to measure a wide range of capacities, by the use of shunt and series resistors, as shown above.

# FIXED-BIAS AMPLIFIERS

More output with smaller tubes results from the proper use of fixed bias.

**H**OW many experimenters, like the author, have looked at a small commercial radio filling a large room with crystal-clear volume and have thought it would be nice to have an amplifier of such small size that would give such high undistorted output. Perhaps you have looked in the back of the set and been amazed to find a single pentode or tetrode such as the 6F6 or 6V6 responsible for all the volume. You have taken down the number of the tube and gone home and immediately built up a little class A1 job, thinking that the use of that tube would cure all amplifier problems. And you have been cruelly disappointed. All voltages, resistances, and loads test exactly as they should to conform to

have put away an attempt like this as a failure, get it out again, for there's fun ahead.

It's ten to one that you used something like the circuit of Fig. 1 when you decided to build a phono amplifier with this magic tube with which to amaze your friends. This is the typical circuit we all know well. You looked up the correct ratings for the tube, used mathematics correctly to determine the resistance values, and bought the right output transformer. Why does the set not work or so much less well than the commercial amplifier? One of the answers is, it uses self-bias, while the commercial probably has some form of fixed bias.

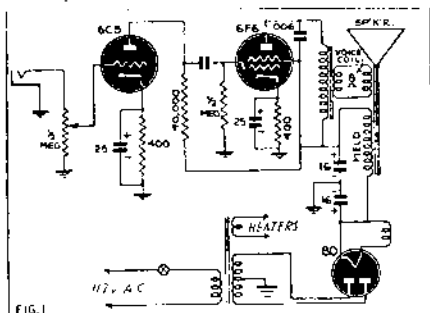

Fig. 1—The common power amplifier circuit.

the ratings given in the tube manual for that tube, and yet at a very low level compared to the level of the commercial set, terrific distortion sets in, and the output stage turns the sine wave on its grid into a dreadful goulash of flattened wave tops and curious peaks in the plate circuit. If you

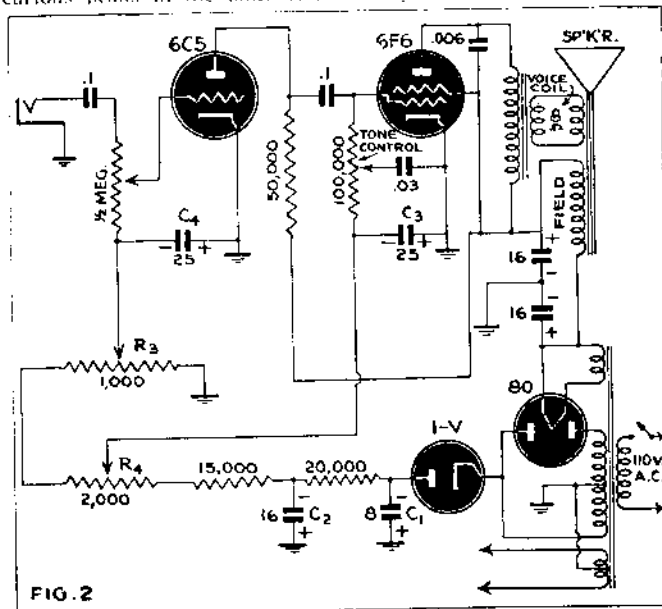
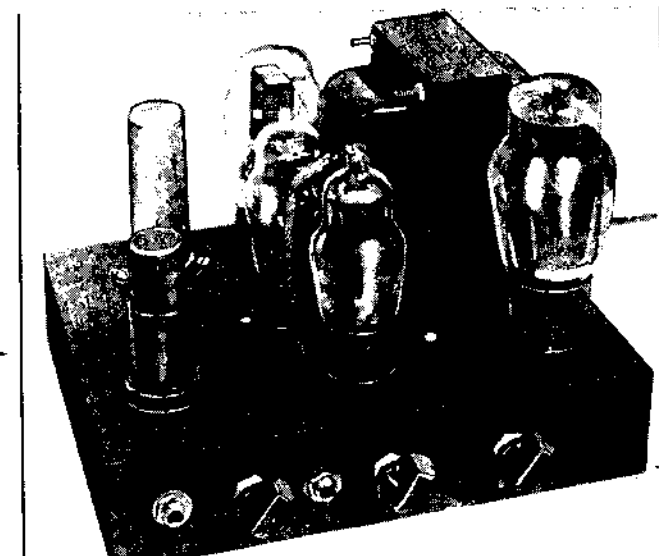

FIG. 2



The complete amplifier described by Mr. Edmonds in this article.

## FIXED BIAS IS FEASIBLE

Let us see exactly what we are up against. In the first place, the ordinary cathode-biased class A1 stage proves to be highly inefficient and low in fidelity for two main reasons: (1) the bias voltage, which should be very stable, is varied by being developed by a varying current, i.e., the plate and screen current of the tube, and, (2) since the effective plate voltage on a tube is measured between plate and cathode, raising the cathode to a positive potential, as is done with cathode-biasing, reduces the effective plate voltage on the tube by the amount of the bias voltage. This last disadvantage becomes important in A.C.-D.C. sets, where plate-voltage is low, and in sets using power triodes, such as the 2A3, where the required bias is very high.

Fig. 2—Here is a fixed bias circuit. The 1-V forms an independent source of negative voltage, and grid potentials can be adjusted with the variable resistors R3 and R4, and are quite independent of any normal changes in the rest of the amplifier. Equipment for hum filtering and decoupling is cut to a very low level, without affecting quality.

As to the first trouble, stability (i.e., voltage regulation) of the bias voltage is of utmost importance, and, for good efficiency, a 1% variation should never be exceeded. Looking at the cathode-biased stage, we see that such regulation is impossible. Some experimenters connect hundreds of microfarads across the cathode, and this no doubt helps. But it cannot eliminate the fact that the bias voltage developed by this method is to some extent dependent on the varying conditions inside the tube, no matter how big a condenser is used. Besides, why waste money buying such huge capacities?

Our primary aim, then, is to make the bias voltage completely independent of the tube to be biased. To get true fixed bias we must begin by grounding the cathode and look elsewhere for a negative voltage which we may apply at the low end of the grid return. Here we see that the class A1 amplifier presents a much simpler problem than the class AB2, chief figure in the nightmare aroused in most experimenter's minds by the mention of fixed bias. First, the class A1 amplifier never draws grid current. This is our prize postulate in dealing with fixed bias for small tetrodes and pentodes, for see what it allows us to do: We may omit practically any combination or value of resistors we like in the grid return, and not worry about voltage drops, since (excepting by-pass condenser leakage) there is never any current whatsoever (under proper circuit conditions) flowing in anything in series with the grid of a class A1 stage.

Second, the ordinary receiving type power tube has no critical grid impedance, and so we may forget about that. All we have to do is to unground the grid return of our 6F6 in the circuit of Fig. 1 (or of any other tube in a similar application—the 6F6 is here used merely as an example) and apply the right bias from the simplest source we find handy—anything that gives 22.5 volts and is stable. Some tubes, like the 6V6, have a fairly low maximum permissible grid resistance. The solution to this problem is merely to use transformer coupling.

## AN OLD-TIME BIAS SYSTEM

One of the most widely used methods of biasing is the type using a resistor in the negative return of the power supply. It is

(Continued on page 45)

# ULTRA RADIO

This single-tube, self-powered super-regenerator is capable of world-wide reception with a fifteen-inch antenna. A special tapped coil eases operation over wide frequency bands.

**T**HE short wave enthusiast who wants dependable reception on bands between 10 and 120 meters will find this receiver ideal. The 117P7-GT tube, which combines a half-wave rectifier and beam power amplifier, is employed as a self-powered superregenerative detector. The super-regeneration makes possible around the world reception with only a 15-inch antenna. Although the entire receiver with the case measures only 5 x 5½ x 3½ inches, many features are included in the design—such as plug-in-coils, tapped coil range-extender, band spread, stand-by "B" switch, and luminous dials.

## CONSTRUCTION DETAILS

In the original model the panel was constructed from a masonite board measuring 5 inches across, 4½ inches tall, and ¾ of an inch thick. No shielding for hand capacity is necessary, for the receiver is very stable. After the holes are marked and drilled, the front side may be given one or two coats of colored brushing-lacquer. After this is dry, the main parts may be mounted and the panel fastened to the

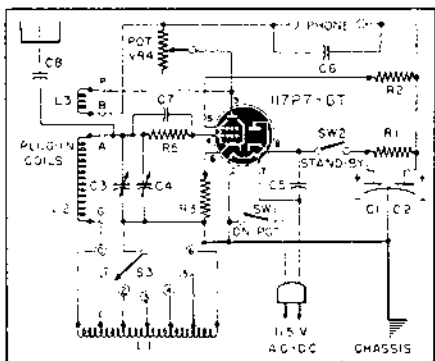

Fig. 1—The Ultra 1-tube all-wave receiver.

chassis, which measures 4½ inches wide, 3½ inches long, and 1 inch tall.

After the parts that are fastened directly

to the chassis or panel are firmly in place, the filter condenser (C1-C2) may be mounted. If not small enough to fit under the chassis, it may be fastened to the side of the potentiometer. (See the picture.) The 1000-ohm wire-wound resistor is mounted on a tie point terminal to prevent short circuiting to the chassis.

The wiring is very simple, but care should be exercised in not omitting any connections. The pilot lamp is optional. If it is used, it should be suited for 120-volt operation, and should be connected across the 117P7-GT tube's terminals 2 and 7. The plug-in coil data shown in Fig. 2 is only approximate, and minor adjustments will be necessary. It is better to have too many turns of wire to begin with, than not enough. All the plug-in coils are wound on 4-prong tube bases.

The broad tuning of the superregenerative receiver is helpful in picking up distant stations, but it tends to make the tuning range for one coil very short on the lower frequencies. It was noted that the opposite was true of the oscillating range. The lower frequencies will allow the detector to oscillate over a longer range without adjustment of the plate coil. Then, it was reasoned, if in some way grid turns could be added or subtracted at will, the range would be extended over a much longer band.

As a result a tapped coil was placed in series with the plug-in coil's grid circuit. (See Fig. 1.) This coil was wound with No. 24 S.C.C. wire on a ¾-inch form 1¼ inches long. It is tapped at the 2nd, 3rd, 12th, 17th and 23rd (last) turn. When selector switch S3 is connected to contact 0, coil CL1 is entirely shorted and reception at the high frequencies is possible with plug-in coil D. But starting with plug-in coil D the range can be extended by switching in a few turns of wire to increase the inductance.

## OPERATING POINTERS

Proper use of the receiver is as important as proper construction. The operating

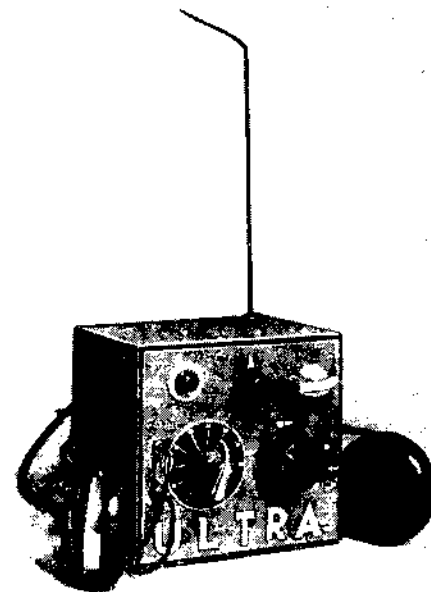

This view of the Ultra with its headphones gives a very good idea of its compactness.

power is obtained from any 110-to 120-volt line, supplying either alternating current or direct current. If direct current is used, the power plug may have to be reversed to get the right polarity. Portable or emergency operation is possible with 90 to 112½ volts from heavy duty "B" batteries. Battery operation was found to be very satisfactory, except for the drain placed on the batteries.

The antenna is made of a stiff length of copper wire soldered to a phone tip, so that it can be plugged into a socket post. The length should not exceed a yard. The antenna can also consist of a few feet of insulated wire, if desired.

The continuous oscillation of the superregenerative type of receiver may cause interference with near-by short wave receivers. If any experimenting is to be done with out-door aerials it is advisable to connect a radio frequency amplifier between the detector and aerial. The use of an out-door aerial is not necessary, and the author

(Continued on page 31)

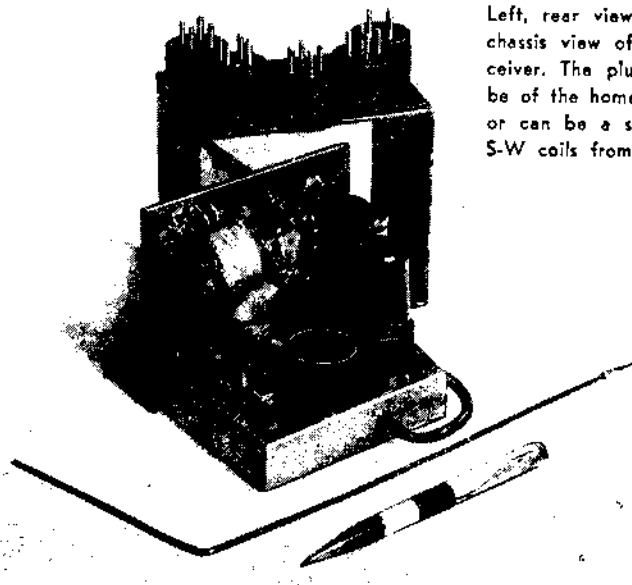

Left, rear view; right, under-chassis view of the Ultra receiver. The plug-in coils may be of the home-made variety; or can be a set of standard S-W coils from an old radio.

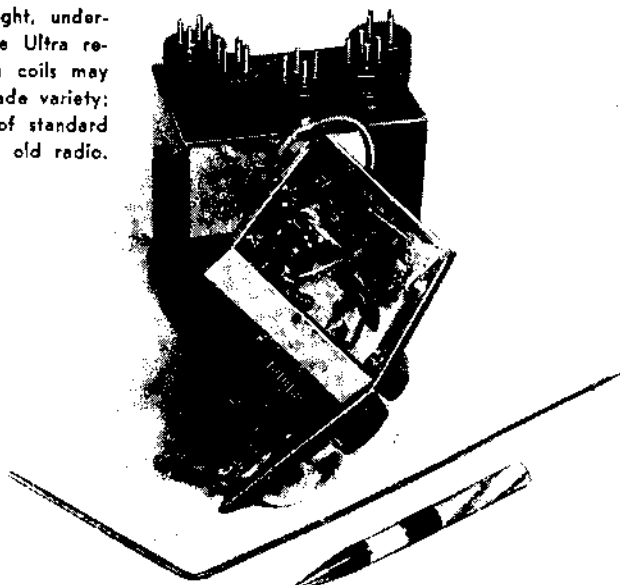

# A Novel Feature in P. A. Systems

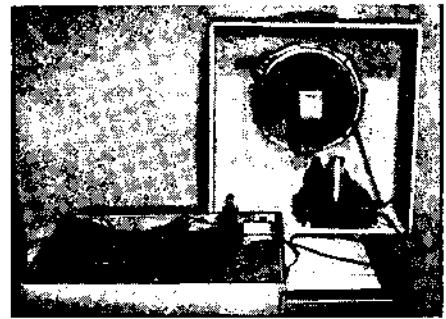

Amplifier and speaker are built in one half, and oscillator and phonograph turntable in the other half of a portable carrying case.

**T**HIS is a good-fidelity, low hum record player and audio amplifier combined with its own phonograph oscillator. The gain is quite sufficient for a low-level microphone and the output stage drives a 12-inch speaker with excellent volume. A standard circuit is used, the two 6V6's in push-pull being driven by a 6SC7 as phase inverter, with a 6J7 as a pre-amplifier stage. During the earlier part of its life, this amplifier used a 6SP5, in the first stage, but the 6J7 was substituted on account of the greater gain obtainable.

Some may wonder why a phono oscillator is included in a record player with its own amplifier. This is one of the most useful features of this instrument. The oscillator has considerable power and when the player is used in a large hall where there is some difficulty in covering the whole place properly, the oscillator helps out wonderfully. Several radios are placed in strategic positions, short antennas are rigged up both on the radios and the

oscillator and the problem of coverage is solved. This is especially useful where there is a great deal of room noise, as at parties and dances, as the only way to be heard all over the hall is to have the sources of sound scattered around at a number of points.

## ANTI-HUM PRECAUTIONS

Some care in building an amplifier is necessary if hum is to be kept down and quality up. This set starts out with a good filter system. The two chokes and three condensers assure proper smoothing of the rectified alternating current, and the careful shielding of the whole signal path right up to the grid of the *second* tube guarantees against 60-cycle pickup from outside sources.

It is unnecessary to say much about the chokes, except that they should be low-resistance and high-current types, preferably rated for double the current to be

drawn by the amplifier. A low-resistance speaker field is also required, anything over a thousand ohms being entirely unusable. If you have a good speaker with too high a field resistance, it may be used as the first section of the choke, and the plate supply lead for the 6V6's taken off immediately after it. The second section of the choke can then be a low-current type, as very little

current is drawn by the first two tubes. Some of the advantages of double-choke filtering will nevertheless remain, as current smoothing is more important in the first stages of the amplifier than it is in the output.

Another important point in reducing hum is to ground all the leads to *one point*. This is a great help in cutting out hum set up in the chassis by the power transformer. As far as possible, all shielding may be brought to the same ground. It may be more convenient to have one ground point for each stage.

The 6J7 is hooked up in standard style. It will be noted that the screen resistor is taken off *after* the decoupling circuit which consists of  $R_6$  and  $C_4$ , instead of running straight from the high voltage as in some amplifiers.

The volume control is not introduced until the signal has been amplified through the 6J7. This gives us a higher level of signal to work with. It was not considered a good idea to use a single volume control for phonograph and microphone, as the present arrangement makes "fading" possible, with a little manipulation, or phono and mike can be mixed.

The 6SC7 was found to give better results both in gain and freedom from distortion, than a 6F8 formerly used in its place.

Phase inversion is accomplished through a partially self-balancing circuit, which may not give as much gain as others, but in my opinion results in greater stability. The only features of note in the output circuit are the grounding of both the transformer core and the voice coil circuit to the common ground.

The mike being used at present is a 5-inch I'M speaker. Used with the amplifier, there is far more than sufficient volume.

It is necessary to talk within six inches of it to make announcements over the oscillator, under which condition it operates satisfactorily.

The whole amplifier is encased in a box which measures 20 x 20 x 12 inches, as shown in the photo, and is thus a handy unit for portable work. The oscillator feature makes it useful for gatherings almost without limit as to the size of the hall.

The oscillator itself uses a standard broadcast coil, and any phono oscillator could be used in its place. I used an ordinary broadcast coil with a small primary, then unwound a number of turns from the secondary and used an old condenser considerably larger than those now in use. This enables me to tune easily to a point right on the high or low edge of the range of any modern

(Continued on page 37)

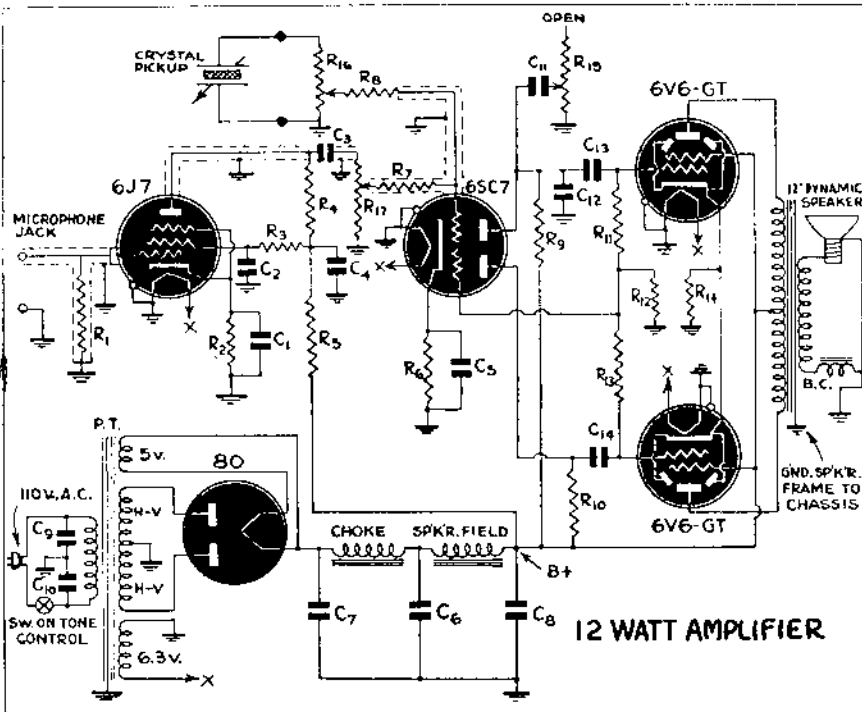
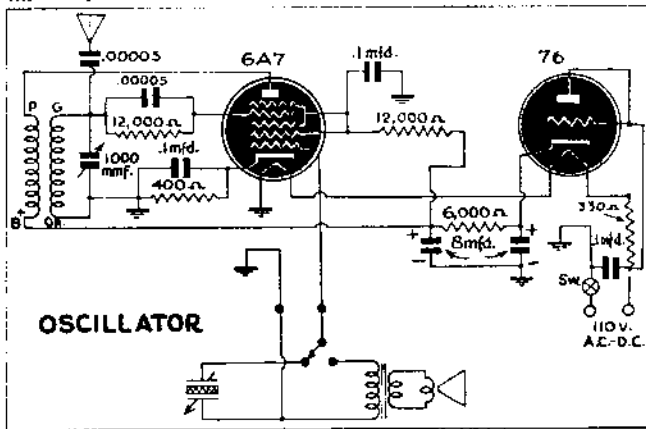

# Dynamic Tube Tester

## Mutual Conductance Meter for Accurate Tests

**W**ITH few exceptions, all the tube testers on the market today are the total emission type. All elements but the cathode are tied together and the emission of the cathode is measured by a D.C. milliammeter. Such testers require few parts and are useful for short and emission tests of rectifiers and output tubes, where the emitting ability of the cathode is one of the major factors. In other types of tubes they have severe limitations, for they give no indication of the tubes' transconductance, abbreviated Sm. (Mutual conductance, abbreviated Gm, means the same.)

Transconductance by formula is:

$$S_m = \frac{dI_p}{dE_g} = \frac{\text{change in plate current}}{\text{for given change in grid voltage}}$$

Thus, if an A.C. signal of 1 volt is impressed between grid and cathode of a tube with normal plate and bias voltages and its A.C. plate component measured in microamperes, the result is a direct reading in micromhos ( $\mu$ Mhos). If the A.C. output is 1 MA:

$$S_m = \frac{dI_p}{dE_g} \cdot \frac{.001}{1} = 1000 \mu \text{ Mhos.}$$

Since the tube's Sm is directly affected by emission, plate resistance, positioning of elements, etc., the test is made under conditions closely approximating actual working conditions. This type of test is greatly superior to straight emission tests. It has even been found in life tests on a number of tetrodes that while emission fell off with some tubes to a point where they might have been rejected by an emission tester, their Sm had actually increased and they were more efficient amplifiers than when first tested.

Figure 1 shows the basic circuit for such a tester. Theoretically the output measuring device should be an A.C. milliammeter of the dynamometer type which responds to the A.C. However, since such instruments are scarce, it has been replaced with a choke L1 to apply the plate voltage, an isolating capacitor C1, a diode rectifier and D.C. milliammeter M1. It will be noted that the output impedance of the circuit comprised of L1, C1, V2, M1 and R2 is quite low. Therein does the Sm test differ from actual operating conditions, for the purpose is to measure the A.C. output into a load small compared to the tube's plate resistance.

### THE REQUIRED EQUIPMENT

Since, due to war shortages, odd parts are to be used, no specific values are given. T1 supplies the 60-cycle A.C. signal for the control grid and can be any step-down transformer, a winding on the power transformer, filament, bell-ringing or even an output transformer, since no current is drawn from it. R1 is to adjust the voltage applied to the grid and can be any value of volume control. It can be set at one volt, or if the meter hasn't sufficient flexibility, it can be put on the panel and set for various Mho scales. This would also be a simpler procedure than switching shunts across the meter for lower range meters. L1 can be a filter choke, audio choke or the primary of an output transformer. It should have low resistance so too great a D.C. drop will not be created across it when

testing power tubes. It should have fairly high impedance at 60 cycles—say at least 30 H. C1 and C2 should be paper capacitors offering low impedance at 60 cycles—2 Mfd, preferably larger.

The meter can be any D.C. milliammeter with a fundamental range of from 1-6 MA, though a higher range could be used if the fixed grid input voltage of one volt was increased. Lower range meters can have their scales extended with suitable shunts. Since tubes vary in Sm from a few hun-

It forms the diode load and is adjusted for maximum meter reading with a given input signal. Once adjusted it can be left set or replaced with a fixed resistor. R4 is the potentiometer (any volume control) for giving the tube its required bias. It must be much larger in value than R5 so that it will not pass too much current due to the drop across R5. It will be a front panel control and will be calibrated. Its setting determined by meter measurement, and listed for each tube.

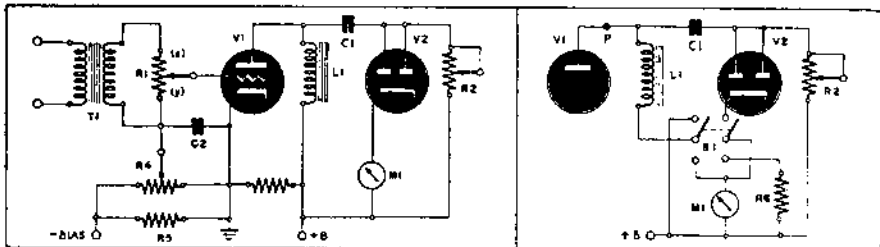

Figs. 1 and 2—Basic circuit of the simple transconductance tester described in this article.

ded to about 6000 micromhos, the scale or scales will have to be readable from approximately 0.2 to 6Ma. V2 can be a diode such as 6H6 or 84. Any tube with good cathode emission can have its grids and plate tied together to operate as a diode, and will work here. R2 can be any potentiometer that will carry the meter current.

The rest of the instrument requires: 1—A tapped filament transformer T2, to supply all tube requirements between 1.1 and 117 v. 2—A source of B supply of about 350 v. with good regulation and bleeder tapped about every 50 v. to supply various plate and screen potentials and bias. 3—An array

(Continued on page 47)

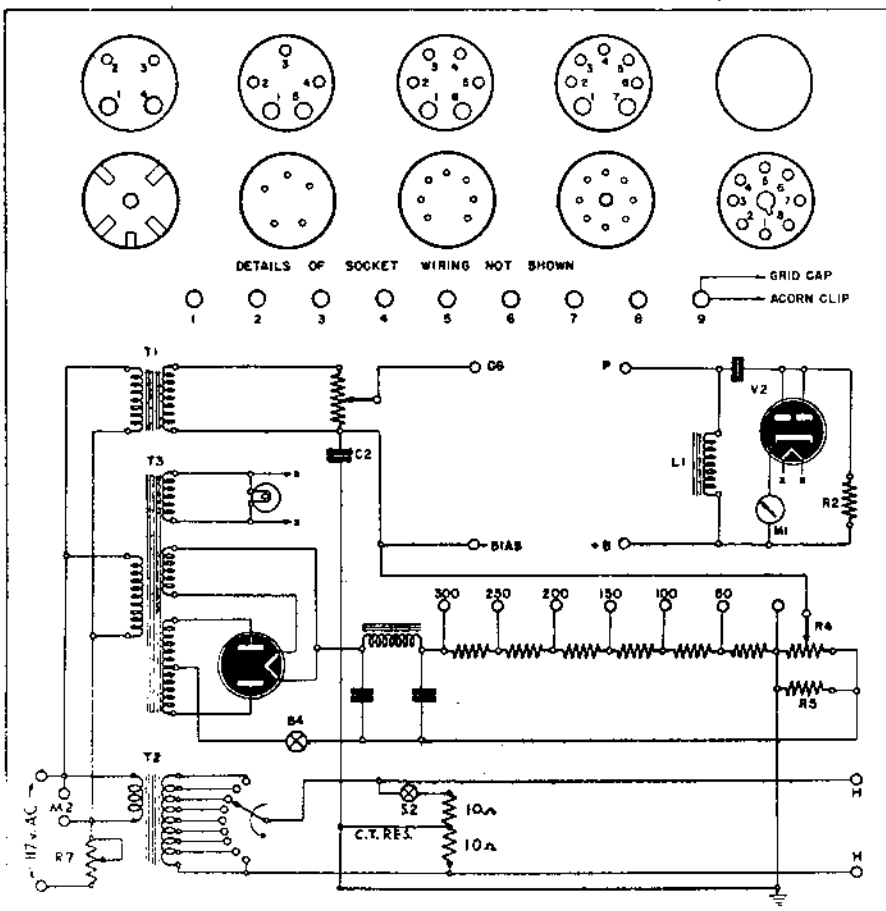

Fig. 3—A complete schematic of the checker. Tube socket terminals are connected in parallel and connected to the numbered posts just below. The actual wiring has been omitted for greater clarity. Connections are made to the voltage posts with the help of a tube manual.

# A Novel Feature in P. A. Systems

**T**HIS is a good-fidelity, low hum record player and audio amplifier combined with its own phonograph oscillator. The gain is quite sufficient for a low-level microphone and the output stage drives a 12-inch speaker with excellent volume. A standard circuit is used, the two 6V6's in push-pull being driven by a 6SC7 as phase inverter, with a 6J7 as a pre-amplifier stage. During the earlier part of its life, this amplifier used a 6SF5, in the first stage, but the 6J7 was substituted on account of the greater gain obtainable.

Some may wonder why a phono oscillator is included in a record player with its own amplifier. This is one of the most useful features of this instrument. The oscillator has considerable power and when the player is used in a large hall where there is some difficulty in covering the whole place properly, the oscillator helps out wonderfully. Several radios are placed in strategic positions, short antennas are rigged up both on the radios and the

oscillator and the problem of coverage is solved. This is especially useful where there is a great deal of room noise, as at parties and dances, as the only way to be heard all over the hall is to have the sources of sound scattered around at a number of points.

## ANTI-HUM PRECAUTIONS

Some care in building an amplifier is necessary if hum is to be kept down and quality up. This set starts out with a good filter system. The two chokes and three condensers assure proper smoothing of the rectified alternating current, and the careful shielding of the whole signal path right up to the grid of the *second* tube guarantees against 60-cycle pickup from outside sources.

It is unnecessary to say much about the chokes, except that they should be low-resistance and high-current types, preferably rated for double the current to be

drawn by the amplifier. A low-resistance speaker field is also required, anything over a thousand ohms being entirely unusable. If you have a good speaker with too high a field resistance, it may be used as the first section of the choke, and the plate supply lead for the 6V6's taken off immediately after it. The second section of the choke can then be a low-current type, as very little

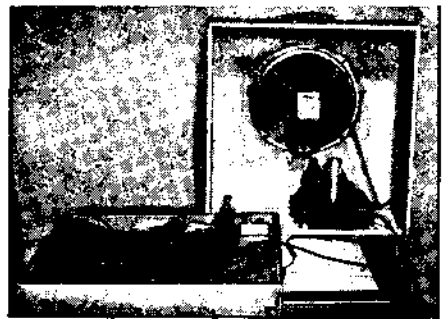

Amplifier and speaker are built in one half, and oscillator and phonograph turntable in the other half of a portable carrying case.

current is drawn by the first two tubes. Some of the advantages of double-choke filtering will nevertheless remain, as current smoothing is more important in the first stages of the amplifier than it is in the output.

Another important point in reducing hum is to ground all the leads to *one point*. This is a great help in cutting out hum set up in the chassis by the power transformer. As far as possible, all shielding may be brought to the same ground. It may be more convenient to have one ground point for each stage.

The 6J7 is hooked up in standard style. It will be noted that the screen resistor is taken off *after* the decoupling circuit which consists of  $R_6$  and  $C_4$ , instead of running straight from the high voltage as in some amplifiers.

The volume control is not introduced until the signal has been amplified through the 6J7. This gives us a higher level of signal to work with. It was not considered a good idea to use a single volume control for phonograph and microphone, as the present arrangement makes "fading" possible, with a little manipulation, or phono and mike can be mixed.

The 6SC7 was found to give better results both in gain and freedom from distortion, than a 6F8 formerly used in its place.

Phase inversion is accomplished through a partially self-balancing circuit, which may not give as much gain as others, but in my opinion results in greater stability. The only features of note in the output circuit are the grounding of both the transformer core and the voice coil circuit to the common ground.

The mike being used at present is a 5-inch PM speaker. Used with the amplifier, there is far more than sufficient volume.

It is necessary to talk within six inches of it to make announcements over the oscillator, under which condition it operates satisfactorily.

The whole amplifier is encased in a box which measures 20 x 20 x 12 inches, as shown in the photo, and is thus a handy unit for portable work. The oscillator feature makes it useful for gatherings almost without limit as to the size of the hall.

The oscillator itself uses a standard broadcast coil with a small primary, then unwound a number of turns from the secondary and used an old condenser considerably larger than those now in use. This enables me to tune easily to a point right on the high or low edge of the range of any modern

(Continued on page 37)

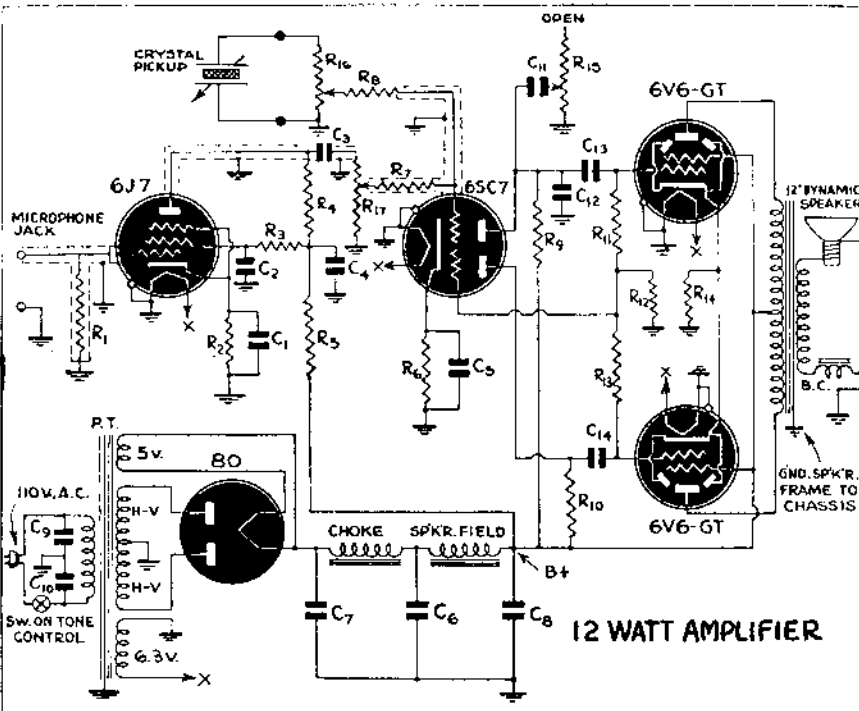
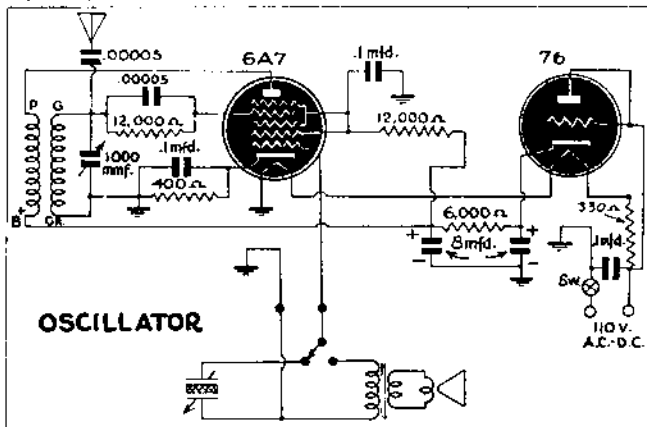

Left, top—The 2-tube phono oscillator attachment. Bottom—Schematic of the amplifier.



# Dynamic Tube Tester

## Mutual Conductance Meter for Accurate Tests

**W**ITH few exceptions, all the tube testers on the market today are the total emission type. All elements but the cathode are tied together and the emission of the cathode is measured by a D.C. milliammeter. Such testers require few parts and are useful for short and emission tests of rectifiers and output tubes, where the emitting ability of the cathode is one of the major factors. In other types of tubes they have severe limitations, for they give no indication of the tubes' transconductance, abbreviated  $S_m$ . (Mutual conductance, abbreviated  $G_m$ , means the same.)

Transconductance by formula is:

$$S_m = \frac{dI_p}{dE_g} = \frac{\text{change in plate current}}{\text{for given change in grid voltage}}$$

Thus, if an A.C. signal of 1 volt is impressed between grid and cathode of a tube with normal plate and bias voltages and its A.C. plate component measured in microamperes, the result is a direct reading in micromhos ( $\mu\text{Mhos}$ ). If the A.C. output is 1 MA:

$$S_m = \frac{dI_p}{dE_g} = \frac{.001}{1} = 1000 \mu \text{ Mhos.}$$

Since the tube's  $S_m$  is directly affected by emission, plate resistance, positioning of elements, etc., the test is made under conditions closely approximating actual working conditions. This type of test is greatly superior to straight emission tests. It has even been found in life tests on a number of tetrodes that while emission fell off with some tubes to a point where they might have been rejected by an emission tester, their  $S_m$  had actually increased and they were more efficient amplifiers than when first tested.

Figure 1 shows the basic circuit for such a tester. Theoretically the output measuring device should be an A.C. milliammeter of the dynamometer type which responds to the A.C. However, since such instruments are scarce, it has been replaced with a choke  $L_1$  to apply the plate voltage, an isolating capacitor  $C_1$ , a diode rectifier and D.C. milliammeter  $M_1$ . It will be noted that the output impedance of the circuit comprised of  $L_1$ ,  $C_1$ ,  $V_2$ ,  $M_1$  and  $R_2$  is quite low. Therein does the  $S_m$  test differ from actual operating conditions, for the purpose is to measure the A.C. output into a load small compared to the tube's plate resistance.

### THE REQUIRED EQUIPMENT

Since, due to war shortages, odd parts are to be used, no specific values are given.  $T_1$  supplies the 60-cycle A.C. signal for the control grid and can be any step-down transformer, a winding on the power transformer, filament, bell-ringing or even an output transformer, since no current is drawn from it.  $R_1$  is to adjust the voltage applied to the grid and can be any value of volume control. It can be set at one volt, or if the meter hasn't sufficient flexibility, it can be put on the panel and set for various  $\text{Mho}$  scales. This would also be a simpler procedure than switching shunts across the meter for lower range meters.  $L_1$  can be a filter choke, audio choke or the primary of an output transformer. It should have low resistance so too great a D.C. drop will not be created across it when

testing power tubes. It should have fairly high impedance at 60 cycles—say at least 30 H.  $C_1$  and  $C_2$  should be paper capacitors offering low impedance at 60 cycles—2 Mfd, preferably larger.

The meter can be any D.C. milliammeter with a fundamental range of from 1-6 MA, though a higher range could be used if the fixed grid input voltage of one volt was increased. Lower range meters can have their scales extended with suitable shunts. Since tubes vary in  $S_m$  from a few hun-

It forms the diode load and is adjusted for maximum meter reading with a given input signal. Once adjusted it can be left set or replaced with a fixed resistor.  $R_4$  is the potentiometer (any volume control) for giving the tube its required bias. It must be much larger in value than  $R_5$  so that it will not pass too much current due to the drop across  $R_5$ . It will be a front panel control and will be calibrated. Its setting determined by meter measurement, and listed for each tube.

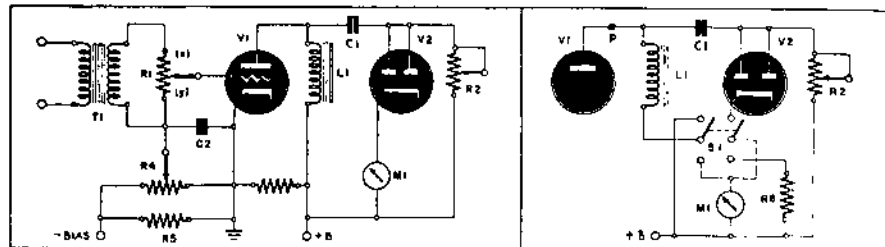

Fig. 1 and 2—Basic circuit of the simple transconductance tester described in this article.

ded to about 6000 micromhos, the scale or scales will have to be readable from approximately 0.2 to 6Ma.  $V_2$  can be a diode such as 6H6 or 84. Any tube with good cathode emission can have its grids and plate tied together to operate as a diode, and will work here.  $R_2$  can be any potentiometer that will carry the meter current.

The rest of the instrument requires: 1—A tapped filament transformer  $T_2$ , to supply all tube requirements between 1.1 and 117 v. 2—A source of B supply of about 350 v. with good regulation and bleeder tapped about every 50 v. to supply various plate and screen potentials and bias. 3—An array

(Continued on page 47)

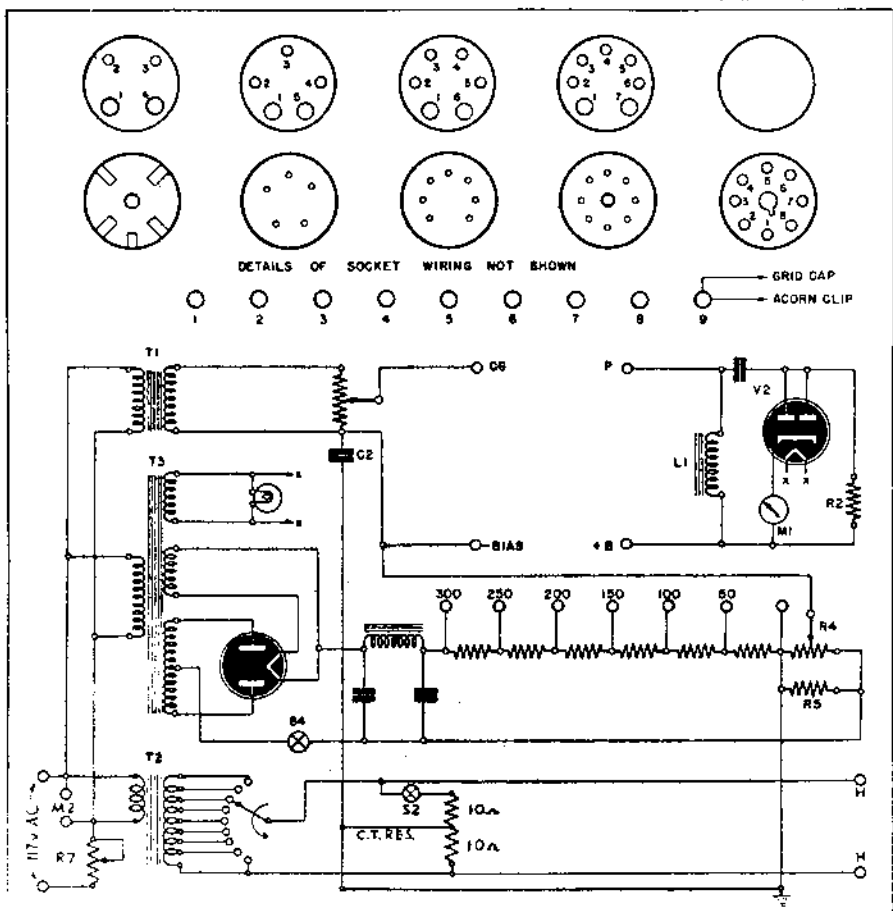

Fig. 3—A complete schematic of the checker. Tube socket terminals are connected in parallel and connected to the numbered posts just below. The actual wiring has been omitted for greater clarity. Connections are made to the voltage posts with the help of a tube manual.

# A Pen-and-Ink Code Recorder

**H**ERE is a code tape recorder you can construct from odds and ends. It will record with fidelity up to 50 words per minute. With this machine you can improve your sending by key or bug. It can also be connected to a short wave receiver, with proper relays and amplifier, so that it will record code directly from the radio to be transcribed later.

The construction of the recorder is very simple. It uses an electromagnet to vibrate a fountain pen in a vertical direction while a paper tape moves slowly in a horizontal direction, thus forming dots and dashes.

The first and most important consideration in the construction is the tape puller. The author used an Instructograph Jr. code practice machine. Plenty of these old units are in existence, and the constructor should have little trouble in obtaining one. If one is not available, it should be possible to build a tape puller with an old spring or small electric phonograph motor, with the necessary governor and worm gear to reduce the speed and supply the variable control necessary for the tape.

As most of the construction will depend on the physical features of the tape puller, the tape guides and manner of mounting the recorder unit will be left to the reader. With the photographs as a guide, he should have little difficulty.

The recorder unit was built on two pieces of Masonite. On the front piece (3 x 4½ x ½-inch) brackets were mounted to hold the armature, electro-magnet and adjustable stop. These brackets are made of 1/16-inch steel but should be even stronger. The electro-magnet and armature came from one of the relays in the cutout can of a 1939 or 1940 Ford. The electro-magnet has a winding of one inch in length on a ⅜-inch soft iron core. It is of No. 30 wire with a total resistance of 12 ohms. The armature has a piece of spring metal riveted onto it, which provides the pen with return action. A piece of 1/16 x ½ x 2-inch strip of iron is soldered onto the armature and this, with a bent piece and an adjustable screw, form the pen holder. The pen is an ordinary fountain pen using ordinary ink. The pen point should be slightly filed so that it will write smoothly when perpendicular to the tape. It passes through a hole on the Masonite to write on the tape which is guided by tinplate guides as seen in the photographs. All that is necessary is that there should

be enough power in the relay movement to pull the pen down with a positive action, and let it go without sticking. The pen should be so mounted that it will move on the paper with practically no friction.

The back piece of Masonite has slots to adjust the position of the pen relative to the paper, making it possible to write three or four rows of code on each side of the tape. Spools of 2 to 2½ inches in diameter ¼-inch thick made of hardwood, were used. The tape is about ¼-inch wide and is made by splitting fifteen-cent rolls of 2¼-inch adding machine paper into three strips by using two razor blades and the

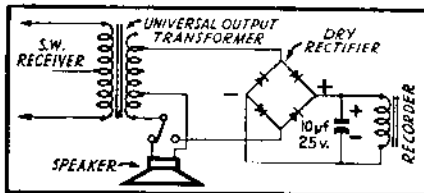

Fig. 2—Hookup for recording from receiver

proper tape guides mounted on a suitable board. The strips are 800 to 900 feet in length, which when recorded on both sides with three rows of code to a side, provide a very economical method of recording. Possibly tape of the proper width can be purchased, but the writer found it so convenient to cut the adding-machine tape into strips of the proper width that he did not bother to search for sources of supply.

The amplifier is connected to the diode circuit of any good receiver, as shown in Fig. 1. Obviously the grounds of the two receivers must be common, as the grid return of the first tube in the amplifier is through the diode load circuit of the detector. The code recorder can also be connected straight across the output of a smaller short-wave receiver, such as the common two-tube regenerator. When so connected a condenser may be run to the plate of the receiver's output tube, and a resistor of .5 megohm or greater is in-

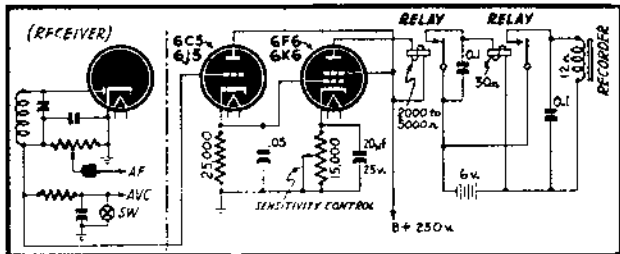
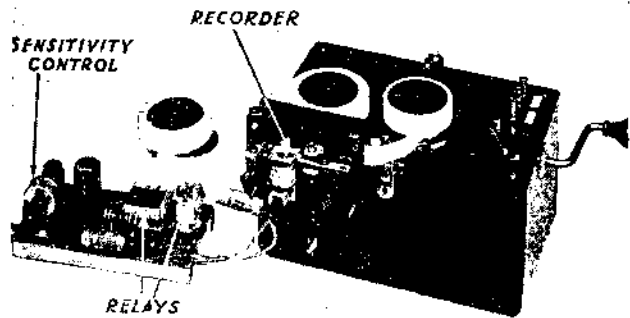

Fig. 1, above—The amplifier circuit, to the right of dashed line. Right—Clearer detail on the recording unit and pen-holding device.



The code recorder together with its amplifier and two rolls of tape.

serted in the grid circuit of the first amplifier tube. Better results will be obtained with receivers using AVC as the output to the amplifier will not vary as much.

For recording from the air the D.C. amplifier with relays shown has proven satisfactory when connected to the diode rectifier on a super-het, with the AVC shorted out. The relays and recorder should be provided with 0.1 mfd. condensers to keep the relays from sticking and prevent radio interference.

If the condensers are too small that will cause chattering; if they are too big the relay will not respond to fast keying. I found that 0.1-mfd. units were correct for my set-up, but different values might be required for other relays.

Because the power requirement is 6 volts D.C. at ½ ampere, some readers might hesitate to build this device. It was found, however, that the recorder would operate quite nicely without a battery, by using a dry rectifier to rectify the output of a shortwave receiver of five or six watts output. To record in this manner the signal must be tuned in and the output transformer disconnected from the loud-speaker and connected to the rectifier by means of a suitable switch. The rectifier should be connected to the 15- or 20-ohm tap on the transformer.

Circuit is shown in Fig. 2. Since the current flow is high, the small meter-type rectifiers will not be satisfactory. Those from old battery-charges or certain loud-speakers work well. Even a broken-down unit may sometimes be used, by checking with an ohmmeter for shorted sections and removing them. Test first one way, then the other, across each pair of discs. In a good unit the resistance is much higher in one direction than the other.

When building a recorder of this type, the reader will find that many improvements will suggest themselves.

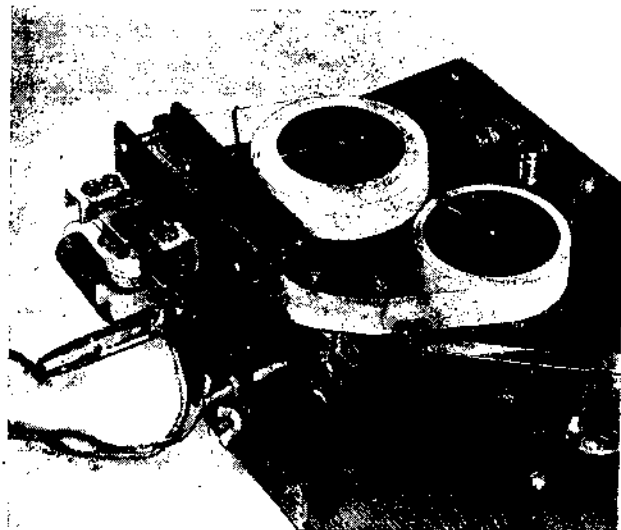

# TRANSMISSION LINES

**T**HE radio trainee is never out of trouble. No sooner does he learn a thing—thoroughly—than he is told something that contradicts it flat. Starting out with simple things like conductors and insulators, he assures himself that he knows just where electricity will go and where it won't. Then he is introduced to A.C. and the condenser, and sees current flowing in a circuit containing a perfectly good insulator. When he gets up to electron tubes, he finds cases in which even the unshakable Ohm's Law appears to be ignored. And when he gets through all these difficulties and knows—or think he knows—R.F. theory, he is up against a new sticker when he runs into antenna problems. He finally does learn how you can have current on a short piece of wire that goes nowhere, and as he fast becomes an authority on standing waves, nodes and loops, he believes that now, at last, he does know radio!

Then he runs into the transmission line. All that he has learned about tuned circuits goes into the discard. The critical and skittish high-frequency currents which (he was told) had to be guided along carefully insulated and isolated wires, cut to the fraction of an inch, are supposed to find their way to the antenna along a pair of carelessly-twisted wires, any length! Travelling along these crude-looking con-

ductors, they are actually expected to deliver power at the end, and that without serious loss. If it is inconvenient to use two wires in the line, one will do! It may also be any convenient length. The new radioman is both bewildered and suspicious. These lines ignore all the rules of radio. They seem so simple as to be impossible to understand. There must be a catch somewhere!

middle of this wire, fairly heavy currents flow. We would expect the impedance here to be fairly low. Out toward the ends, voltages rise and current drops; the impedance becomes higher, in other words. At the ends we have practically infinite impedance (no place for the current to go), zero current and high voltages. This high voltage is due to crowding together of electrons at one end of the wire, with corresponding scarcity at the other end. As soon as the exciting voltage drops, these electrons start to rush back again. The radioman says they are *reflected* from the end of the wire. The result is that we have two sets of waves on the wire—those due to the impulses from the transmitter, and the reflected waves. If the wire is cut to a suitable length (a half-wavelength for example) the two sets of waves re-inforce each other and we have a *standing wave*.

## AN INFINITE TRANSMISSION LINE

Standing waves can take place on wires other than carefully-cut antennas. It was because of unpleasant and unexpected problems on the first A.C. power lines that that they were first brought emphatically to the attention of the engineering profession. These lines showed queer characteristics—insulators would pop at certain—always the same—points, though voltages were kept well within the supposed bounds of safety. At other points the conductors would burn out continuously. Investigators rushed to the scene of trouble found voltages many times higher than that supplied by the generator at the points where the insulators kept on breaking down. Amperes were practically nil. At the other trouble points, fantastically heavy currents would be found, with no voltage to speak of. *Reflection* was the reason, though it was some time before the engineers found it out, and longer before they discovered the remedy.

To go over the ground they did, let us study a line like that of Fig. 1. This may be a power line, or the more familiar radio line, consisting of two pieces of wire about four inches apart. It may also be the well-known "doublet lead-in" (two pieces of insulated wire, more or less tightly twisted), a piece of co-axial cable, an ordinary telephone line, or even a single length of wire. Fig. 1 (b) is the common transposed radio lead-in.

For the purposes of our study, we are going to imagine this line *infinitely* long. It just isn't going to end! (No one is planning to construct such a line—thinking about one just makes it easier to imagine some of the things that happen on an ordinary transmission line, complete with beginning and end.)

Our "infinite line" (yes, that's all an infinite line is) is now connected to a source of power. We may attach its ends to a 60-cycle generator, or terminate them in a loop of wire and couple it to the output of a radio transmitter. We may

expect to put some power into it, as the two wires have a certain capacity to each other (or the single lines to earth). We can consider it a sort of condenser, and expect a charging current to flow. But as current flows into the line, it meets with some resistance, and as the advancing cur-

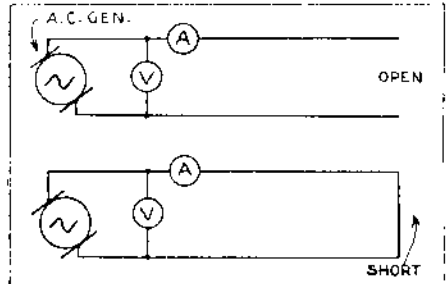

Fig. 2—How the characteristic impedance of an alternating-current transmission line is arrived at.

rent builds up a magnetic field around the wire, it also has to overcome some inductive reactance.

## WHAT THE LINE IS MADE OF

The line then looks to the current very much like the structure of Fig. 1 (c). For purposes of study, it can be broken down into a number of parallel lengths of wire, each having a certain amount of inductance and resistance and with a certain capacity between each length. You can make your lengths a centimeter or a mile—it makes no difference.

It should be quite possible to measure the impedance of such a line, if it were not for the fact that it is infinitely long, and measuring the infinite is not a practical proposition.

We can measure the impedance of such a line, though, and do it with a rather short section. Fig. 2 shows how. We first measure the section with the ends open and then with them shorted. If the section is made short enough, the impedance when open-circuited should be practically in-

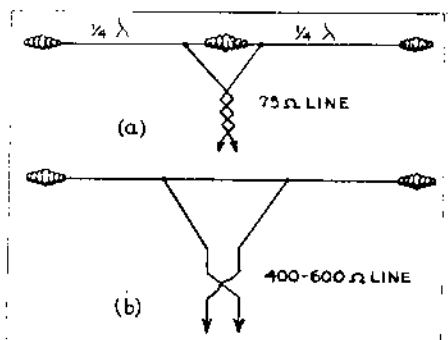

Fig. 3. (a)—Ordinary "doublet antenna" with low-impedance lead-in. (b) A high-impedance doublet.

finite, and there will be no measurable impedance when it is shorted. If we lengthen the lines a little, the open-circuit impedance drops (due to the increasing capacity), while the short-circuited impedance rises (because of the inductive reactance of the lengthened wire).

Obviously, if the line were made long enough, there would be little difference between the short- and open-circuited impedance. Actual experiment with a few

(Continued on page 46)

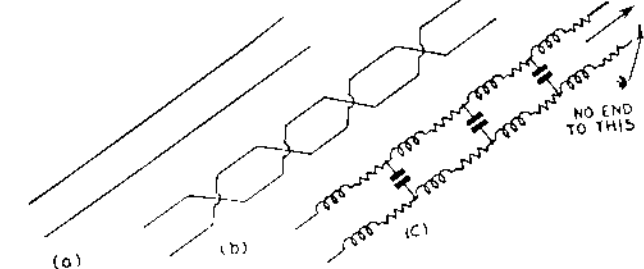

Fig. 1.—At (a) we have a standard radio transmission line, and at (b) the same line as it often appears in practice, with transpositions. (c) shows how such an "infinite" line looks to the radio-frequency currents flowing through it.

Transmission lines really are as simple as they look, however, as we hope to show immediately. "But" says the trainee who has been studying up a little, "isn't this contrary to everything we have ever learned about radio? And if it's simple, what is this impossible-named 'iterative impedance' we read about? An impedance that remains the same whether you have a mile or ten of line, and doesn't even change with frequency. Doesn't this contradict all our ideas of A.C. behavior?" It does, and since the road to knowledge lies through harmonizing contradictions, we are on the way to learning something about transmission lines—and about radio!

Note that high-frequency currents can flow back and forth on a single piece of wire connected to nothing. (We can set up such currents by exciting a similar piece of wire with a transmitter, a few feet away from our "free" aerial.) At the

# CAPACITOR CHECKERS

## Wheatstone bridge circuits and novel oscillators are combined to make three good instruments

**A**T ONE time or another the experimenter, amateur or serviceman is faced with the problem of measuring an unknown capacitor or resistor or perhaps the measurement of one that may have altered in value.

To enable measurements to be taken with some degree of accuracy, most apparatus for this purpose is constructed around the principle of the Wheatstone Bridge, and all of the bridges described in this article employ those principles.

The Wheatstone Bridge in its simplest form is shown in Fig. 1. It consists of a symmetrical network of six arms, one containing a source of current such as a battery or oscillator, another a detector, which may be a pair of phones or a galvanometer. When the impedances of R1, R2, R3, R4 are in proportion, no current flows through the detector arm because points A and C are at the same potential. This condition is realized when  $R1/R2 = R3/R4$ , which is the same as  $R1 \times R4 = R2 \times R3$ . From the above it will be seen that if three of these resistances are known, the remaining one can be calculated.

In Fig. 1 the resistor R4 is the unknown, but if we make R3 variable as in Fig. 2, then by altering this resistor (R3), a point may be reached where the detector will show no reading, as points A and C will be at the same potential. This is

from 10 to 100,000 ohms, and of capacities down to 100 mmf., with a reasonable degree of accuracy. The bridge is energized by a Neon lamp connected as a relaxation oscillator. The A.F. transformer is an ordinary broadcast-receiver type with a ratio of 3/1 or 5/1. The condenser C1, value .005 mfd, is connected across the neon lamp and determines the frequency of oscillation. This value may be altered to produce a suitable note in the phones by substituting various values of C1. A high resistance R1, of 0.5 meg., is connected in series with the transformer and neon to limit the current passed. The D.C. voltage supply is determined by the neon lamp employed. One operating around 100 volts is suitable.

R2 and C2 are the standards of resistance and capacity respectively. They should have close tolerances, preferably 1% or 2%. Variable resistor R3 is of the wire-wound potentiometer type with a value of 10,000 ohms, "linear taper".

### HOW TO OPERATE THE BRIDGE

- (1) Connect to D.C. supply.
- (2) Connect a pair of headphones to the

tion on the resistance range will hold good for capacity also. As the current drain is very small it is suitable to use "B" batteries as a D.C. source.

A small self-contained portable bridge is shown in Fig. 4. This unit may be built into a box measuring 7 by 5 by 4 1/2 inches. The range of measurement is from 100 ohms to 10 megohms and from 10 mmf. to 10 microfarads. The tube oscillates at a low frequency to energize the bridge, and a pair of telephones are employed as a balance indicator. "B" voltage of only 6 to 9 is required. This can be supplied from a "C" bias battery. The tube can be almost any battery type triode. The method of operation is similar to the previous one. This potentiometer is also of the linear wire wound type, so that its resistance is proportional to length of element. It should be calibrated against known values of resistance and capacity. The resistors R1, R2, and capacitors C1, C2, C3, should again be of close tolerance as they are the standards. This unit may also be used as an A.F. oscillator for providing signals when testing the A.F. stages of receivers and amplifiers.

The third bridge—shown in Fig. 5—utilizes the 6E5 magic eye tube as the balance indicator, so doing away with headphones and enabling greater accuracy to be obtained, as well as a greater range of measurement. This bridge will measure resistances from 10 ohms to 10 megohms and capacities from 10 mmf. to 10 mfd. It incorporates a leakage test using a Neon lamp and also has provision for measurement of power factor. When constructed with close tolerances it is a most versatile instrument, and should help fill the need of servicemen for a reliable and portable instrument.

### EASILY BUILT AND CALIBRATED

The instrument is A.C. operated and completely self-contained. There is nothing difficult in its construction and it is quite easily calibrated against known values. If possible a resistance box should be used for the calibration. This will ensure a greater degree of accuracy. When an unknown resistance or capacity is connected across the C and R terminals and the range set to the appropriate position, the potentiometer is turned until maximum shadow is indicated on the 6E5. The value of the unknown element is then read on the calibration scale. When testing condensers, if balance is difficult to obtain, probably the condenser has a large loss. The variable 2500 ohm resistor in series with the 1 mfd. condenser will assist in obtaining a balance. This resistor is also used for the measurement of power factor. It should be calibrated in power factor-percent. The method of doing so is as follows: Temporarily short-circuit the 1 mfd. condenser and balance the 2500-ohm variable resistor against fixed standards of resistance placed in the C and R terminals. These standards will range from approximately 80 ohms for 2% to 2400 ohms for 60%.

(Continued on page 46)

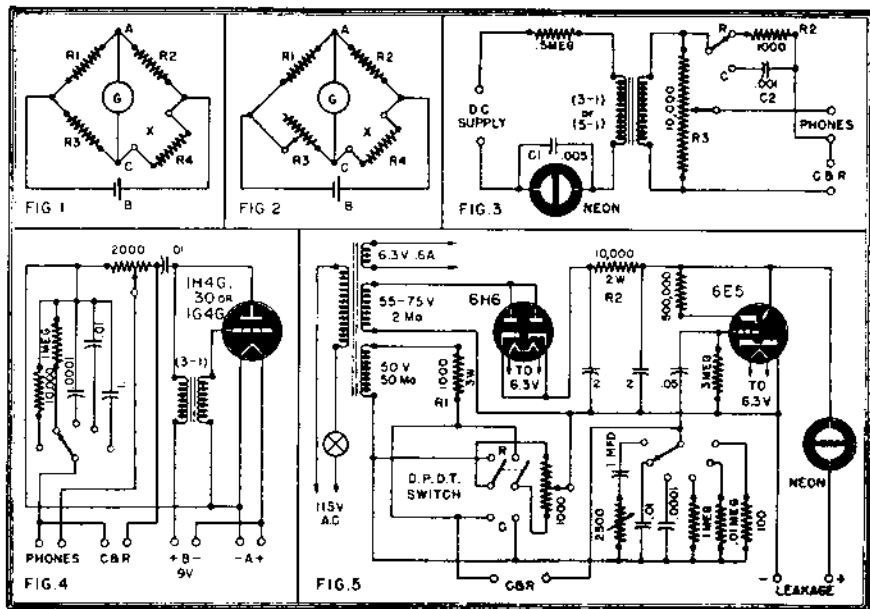

Fig. 1—Wheatstone bridge circuit. 2—Practical adaption, with one variable arm. 3—A D.C.-operated checker. 4—Circuit using tube oscillator. 5—A resistance-capacity checker.

known as the null-point method. It can be readily seen that by employing R3 as a standard against which to check the unknown (R4), a large range of values may be measured. Let us suppose that R4, the unknown, is higher than the maximum value of the standard R3. If R2 is made 10 times R1, then R4 at balance is 10 times R3. This point illustrates a very useful quality of the bridge method, that of extending the range of comparison beyond that of the standard.

Fig. 3 shows a simple practical type of Wheatstone Bridge, which may be employed for the measurement of resistance

terminals provided.

(3) Connect the resistor or condenser to be tested across terminals C and R.

(4) Set the switch to the C or R standard.

(5) Rotate the potentiometer knob until the audio note provided by the relaxation oscillator is no longer heard in the phones or is at a minimum. The scale of the potentiometer is calibrated, this being done by placing known values of resistors and condensers across the C and F terminals. A reversing switch may be incorporated to reverse the bridge action, then calibra-

# SHORT-WAVE INTERFLEX

Truest high-fidelity is obtained with a crystal detector. This old-time circuit has crystal quality combined with tube sensitivity.

**T**HE long-scorncd crystal detector is still unchallenged as the best from the standpoint of fidelity, in spite of all modern technical advances. All that is necessary to prove this is to hook one up to the input of a really good modern amplifier, and listen to a good local station. The improvement over a high-fidelity band expanding superhet, or even T.R.F. receiver, is striking, and one does not have to be a musician to appreciate it.

The crystal is well ahead from the standpoint of simplicity, too. No other detector is as cheap to build or as foolproof to operate. In spite of these facts, two things have kept the crystal out of common use. First is the troublesome and time-wasting process of getting the cat-whisker properly adjusted, and of keeping it so. Second, the crystal's lack of amplification limits its range to a few miles under most normal conditions.

The modern fixed crystal completely eliminates the first obstacle. A good fixed crystal requires less attention and adjustment than a vacuum tube.

Several attempts have been made to overcome the second difficulty. Some have been successful, others not. As already stated, adding a good amplifier makes the crystal a practical receiver for local stations. High, long aerials may increase its range to hundred miles or more. The lack of selectivity in the ordinary crystal circuit is a further obstacle, and to gain distance without interference it is necessary to use vacuum-tube circuits with the crystal.

Among the most practical of such successful circuits were the Harkness Reflex and Hugo Gernsback's Megadyne and Interflex. The set I am about to describe is a modernized and considerably changed version of the famous Interflex. Though the Interflex was put out in three forms—straight, balanced and regenerative—I am following the original set.

On examination the schematic can be broken down into three parts—the crystal detector, audio amplifier (which includes both tubes), and the power supply. In my case the second tube was so hooked up that it could be used as an amplifier in connection with other experimental work. The set could of course be built in one unit if desired.

The crystal detector is hooked up in standard fashion, the only difference between it and any other being that instead of having a pair of phones and a phone condenser across the output it has the 500,000-ohm gridleak and the grid-cathode

capacity of the tube. This manner of connecting a crystal detector to its audio amplifier deserves some attention. Instead of using a transformer with its attendant losses, the Interflex uses a direct coupling from the crystal to the audio grid. The only voltage present in the detector circuit is the signal voltage. The most important purpose of any coupling device is to isolate the plate voltage from the next stage, while letting the signal pass through. Therefore there is no reason here for using any coupling other than an ordinary piece of copper wire.

Construction of this is too simple to warrant much discussion. If it is the builder's desire to hook it up all in one unit, the filaments may all be hooked in series and a line cord of approximately 200 ohms used. The condenser in the antenna circuit will be found useful in increasing selectivity. Some people are a bit puzzled by the low resistance of the first tube grid resistor, but if you remember it is an audio amplifier and not a detector, the resistance looks more like normal.

There are only three cautions to be impressed: 1—Keep all leads as short as possible. 2—Do not ground the set except as shown in the circuit diagram. 3—When using the additional power amplifier section be sure that the leads to it are properly connected. After you have finished the construction, it is wise to check the wiring at least twice to make sure you have no mistakes.

This set is a joy to handle—there are no tricky regeneration circuits to whistle and howl at you. There are no image interference problems as with a superhetero-

How the Interflex looks. Layout details may be modified to fit the constructor's ideas.



dyne, no distortion with strong signals as with condenser-leak detectors, and best of all, *plenty of volume*. It is a really fine high-quality set for either the fellow who is about to build his first A.C.-D.C. receiver or the experienced builder who wants to get the best possible short-wave set with the least cash outlay.

If regeneration is desired, it can be added by using any of the common short-wave regenerative circuits. A tickler can be inserted in the plate circuit or the cathode return brought to a tap in the grid coil, using standard regeneration control means.

A list of the parts used in constructing this set follows:

#### Parts List:

C1, C2—140 mmfd. variable  
 C3—8 mfd., 35-volt electrolytic  
 C4—.003 mica or good paper  
 C5, C6—16 mfd. 250-volt electrolytics  
 C7—10 mfd., 35-volt electrolytic  
 C8—.005, (if required)  
 R1, R4—0.5 megohm, ½ watt  
 R2—9000 ohms, 2 watts  
 R3—0.25 megohm, ¼ watt  
 L1, L2—Standard plug-in coils  
 CH—Any good A.C.-D.C. choke  
 V1—6F5 or 6SF5  
 V2—25Z5 or 25Z6

Amplifier:  
 R5—600 ohms, 2 watts  
 RL—Line cord resistor, 270 ohms  
 RL amp.—Line cord resistor, 300 ohms  
 V3—25A6 or 43

If the set is built in one unit, with all filaments in series, the line cord should have a resistance of 200 ohms.

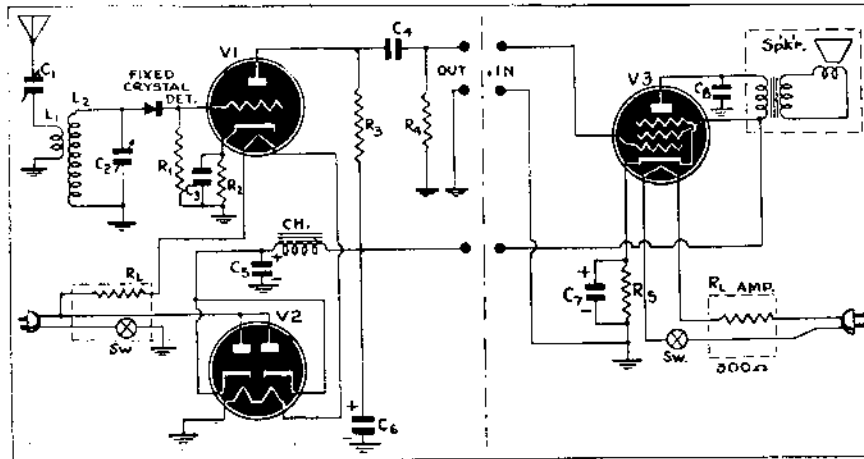

Schematic of the Short-Wave Interflex, including its semi-independent amplifier unit.

# Two Cigar-Box Radios

## A Special Regenerator and a Standard 3-Tuber

**T**HE circuit sketched is a champion. Tuned to any one of the four Toronto broadcast stations or WGR or WBEN, Buffalo, one 6A8-GT will drive the 3-inch speaker at any time of the day, and will pick up a few more, including WHN, New York, in the evening. Volume is quite adequate for a personal radio—all one should use in a hotel to avoid disturbing guests in adjoining rooms.

The circuit makes any explanation almost unnecessary. The inner two grids of the 6A8-GT are used as grid and plate of a grid-leak detector, the output of which is transformer-coupled to the control grid as an audio stage. Exceptional stability is an outstanding feature of the circuit. Good

shot primaries. I heated one until the primary would push out and rewound it from the other secondary. Building backwards in this fashion, it was hard to get enough turns on the primary to keep the turns ratio low, so the condenser eliminates a slight tendency to distort on loud highs otherwise noted.

As for power supply, almost any type will do—I used a 6K7-G for a rectifier. Either a capacity-resistance or capacity-inductance filter is satisfactory the latter giving slightly better speaker volume. Hum was non-existent in either case. The choke was a tiny output transformer that I could never match with anything. Note that when resistive filter was used the bleeder was placed at the cathode rather than the B-plus side to avoid the considerable voltage drop resulting from forcing this surplus through the filter.

The rather large antenna coupling condenser is necessary for speaker operation as is an antenna of approximately 40 feet overall length. For headphone operation, selectivity may be increased by reducing antenna length or using a small coupling condenser.

A coil of 90 turns of No. 28 enamel wire, close-wound on a 1½-inch form, will prove suitable, as will any ready-wound broadcast coil. The tap for regeneration on my set was taken off at only two turns from the ground end. While I would not like to try to explain how, the action of the set leads me to believe that there is some further regenerative effect due to some special kind of coupling inside the multi-grid tube.

The set is at present on a cigar-box breadboard, but I intend shortly to put it in a "cabinet" similar to the set shown in the photographs. This is the receiver I carry in my grip, and really is a honey—2 6SF5's and a 32L7. A circuit diagram is appended in case anyone should be interested, though there is absolutely no departure from the orthodox circuits—which by this time should be known to everybody—in this receiver.



Layout of the three-tube broadcast receiver.

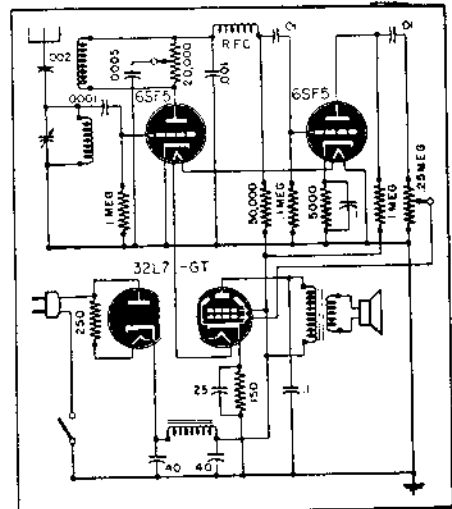

A compact three-tuber for travellers' use.

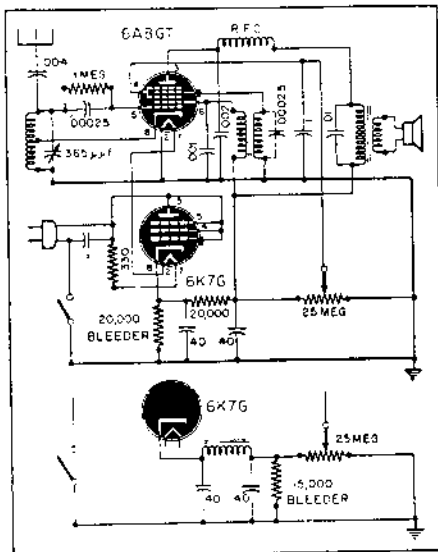

An original reflex circuit, whose efficiency may be due to some coupling in the 6A8 tube.

R.F. filtering and the fact that but two turns of regeneration are used account for this. The latter accomplishes another useful purpose—it permits operation of the regeneration control at near full setting, insuring near-maximum plate current and consequently improved power output for speaker operation. Tuning squeals are practically eliminated.

The audio stage is quite conventional. Ordinarily one wouldn't need the .0008 condenser across the transformer secondary if it's a reasonably good one. I had two from an ancient Marconi—both with



The set looks well in its cigar-box cabinet.

## Neon Checker from Old Parts

The little voltage tester offered here is made from odds and ends available to most experimenters and is very useful if care is used in calibrating it.

The indicator is a ¼-watt neon bulb connected to a potentiometer so that the voltage can be adjusted till the bulb just "strikes." This striking voltage is very constant; though it is different on A.C. and D.C. and calibration curves must be run for each, using known voltages. The tester has an A.C. range from 1 volt to 300, and a D.C. range from 75 to 300 volts. The ranges can be extended higher by the addition of a couple of resistors.

The main feature of the set is the transformer, which is an ordinary push-pull output type. Other parts needed are a 10,000-ohm wire-wound potentiometer, the neon bulb, several resistors for multipliers, several tip jacks, a pair of test leads and a jumper with phone tips on each end, and dial plate and knob.

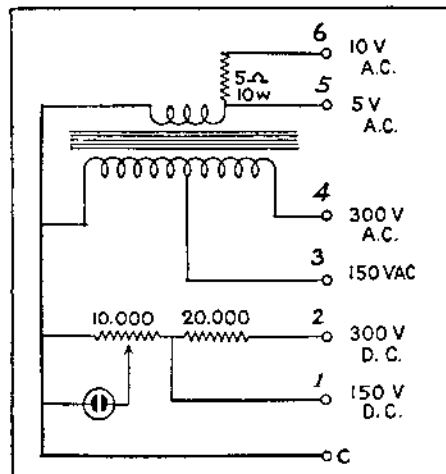

# Record Changers

## Notes on Maintenance and Repair

**W**HAT is the most efficient method of attack on record changers in need of repair? The answer: simply the same logical approach used on electronic circuits. Putting it into general terms:

*Visualize the mechanical actions step by step in a manner similar to the way electrical reactions are considered stage by stage in a radio set.*

Many faults are so logical as to be perfectly obvious to anyone possessing sufficient curiosity to try a few simple adjustments.

The greatest variety of troubles occur in newly installed machines. It is improbable that brand-new phonographs will be sold for some time. The statement still applies to machines that have been transported considerable distances and set up in new locations. This appears less of a paradox when the causes are considered in detail. It is easy to see that only a minor misadjustment can interfere with the working of the entire unit. The cause of the breakdown is all too often due to the set-owner's ignorance of proper care and operation of the set. Since prevention is the best cure in this case, some of the more usual causes are discussed first.

### 1. Improper Unpacking

The unpacking of any radio-phonograph consists of more than merely removing it from the shipping box. During shipment the radio chassis and phonograph unit are both secured by "packing bolts." These are usually painted red for easy identifica-

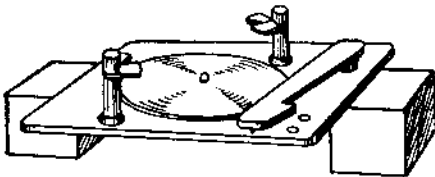

Fig. 1—A simple system for blocking up the record changer on the bench to make repairs.

tion and when removed leave the radio and phono unit floating freely on rubber or spring mountings.

#### Symptoms

Jamming of the mechanism in the midst of a repeat cycle or failure to operate at all may be due to binding of the mechanism against the cabinet, caused by packing bolts being tightened down.

If a rim-drive motor spins but the turntable does not revolve, the motor may have a separate packing bolt preventing it from floating on its pivoted mounting. This particular bolt is sometimes never removed but merely loosened enough to free the motor. In this case, it may not have been loosened enough to allow for wearing-in of the moving parts.

### 2. Improper Packing

The above method of packing would be used by the factory or a service man in preparing a set for shipment, but the customer often ships the set himself. He may fail to safely secure loose parts (probably not even using a box if he intends to carry it in the family car. That physical damage can occur is obvious, but loss of

rubber or spring mountings can make it impossible for the phono unit to rest on an even keel. This may interfere a great deal with the balance of the many small tension springs used to position the levers.

#### Symptoms

Dropping records two at a time, jamming one side of a record and dropping the other; starting too far in or outside the edge of the record; repeating before the selection is finished; all these faults are typical of a unit that is not level.

Don't forget to check the floor! Older buildings sometimes settle badly and can contribute to faulty operation unless the

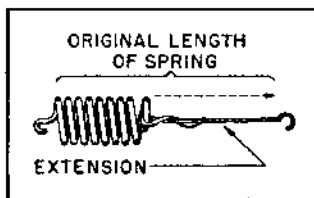

Fig. 2—Replacement for broken spring.

legs of the set are leveled by placing a block under one corner. Don't guess; use a spirit level.

### 3. Forcing of Mechanism

This is probably the most prolific source of serious trouble. Many people have become familiar with old style hand operated phonographs, and seemingly cannot overcome the habit of reaching for the pickup arm when it is time for another record to start playing. They inadvertently forget that something else is handling the pickup, the sensitive gears and cams of the repeat

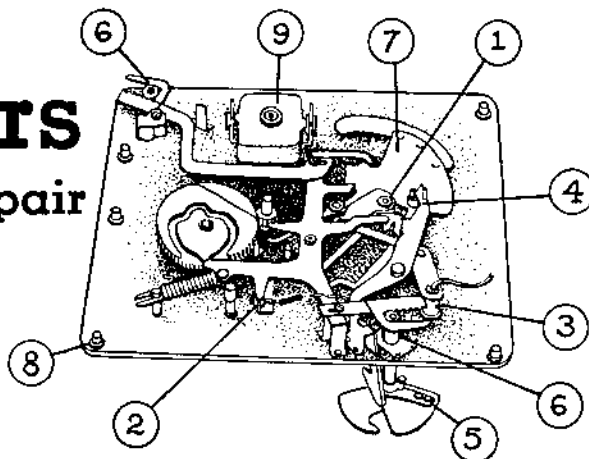

Fig. 3—Bottom view of changer. Numbers in circles refer to Fig. 4, below.

mechanism located below the motor board. Levers can be bent and springs broken this way, but it usually occurs that adjustment screws are forced out of position. These are equivalent in importance to the tuning screws in R.F. and I.F. transformers.

#### Symptoms

Failure of the needle to come down at the proper place on the edge of the record and failure of the repeat cam to disengage, resulting in the repeat action occurring over and over without stopping to play a record is one of the typical faults resulting from such mal-operation. The list of troubles attributable to this cause may exceed the imagination. Care used in placing the blame for the cause of breakdown may help to prevent its recurrence.

If the set owner has developed a habit of operating his set in an improper manner, he may not be aware of the bad effects since they appear gradually. As long as his way of doing things gets results he will persist in doing them that way. A few tactful remarks can result in the discovery of such a situation and, once the true cause of the trouble is known, a bit of helpful advice to the owner will eliminate a possible callback.

### 4. Use of Old Records

An example of unintentionally improper operation is the use of phonograph records (Continued on page 38)

ADJUSTMENT ON:	SYMPTOM OR TROUBLE
1. Friction Clutch on tripping pawl	Too loose—Repeat mechanism fails to trip. Too tight—Repeats grooves over and over. (using a good record)
2. Height of Pick-up (Turnbuckle)	Needle drags on top record when 10 or 12 records are stacked on turntable.
3. Needle landing place for 10" records. (Set screws on pick up shaft)	Needle misses edge of record or starts too far in on 10" records.
4. Needle landing place for 12" records. (Eccentric stud)	Same as above but for 12" records. This must be set after adjustment for 10" records.
5. Distance between Selector Blades. (Screw and lock nut)	Record selector blades strike the edges of records instead of separating them and sliding in between.
6. Distance of rotation of Selector Blades. (Set screw on Selector Blade shaft)	Records, when released, fall in a lopsided manner instead of both sides simultaneously.
7. Repeat Lever (Requires bending or reshaping)	Repeat Lever inoperative because of too forceful handling by inexperienced operator.
8. Leveling of player. (Spring retaining screws at each corner)	Needle may fail to slide into starting groove of record if turntable is not level.
9. Oiling. (Use SAE No. 10 oil on motor and petrolatum on other moving parts)	Squeaks that can spoil listening pleasure and "dragging" of motor during operation.

Fig. 4—Table of the most common record-changer troubles. The numbers refer to Fig. 3.

# TWO-TUBE FM RECEIVER

**T**HE receiver is usually not only the weakest link in an FM set. It is also the trickiest piece of equipment to construct, and completely out of the range of the average experimenter's facilities in these days, unless some means of getting around the use of the big FM superheterodyne is found. The receiver about to be described is not a time-tried circuit. Reception of FM signals has been satisfactory on a set of this design, but there is plenty of room for refinement, improvement, and such general pattering around as the ham experimenter loves.

In attempting to get around the use of the big FM super, let us see just what we are up against. The U.H.F. ham working with AM gets around it by falling back on the time-tried super-regenerative detector, self-quenched or otherwise as the case may be. What relation do these two types of receivers bear to each other? If we analyze the superhet, we find that basically it is built around a diode or triode detector ignominiously shoved away unnoticed under the title of "second detector stage." The rest of the tubes, while placing the greatest drain on the amateur pocket and causing him to consume much headache powder, are actually nothing but devices to increase the selectivity and boost the signal a bit. These are very laudable ambitions, but we find that if we just turn the second detector into a triode (if it isn't one already) and add the simple, well-known super-regenerative connection, all the complicated R.F. and I.F. systems may be calmly pushed aside, and we still have a receiver of very passable gain and enough selectivity to get by on.

Now to apply our findings to FM equipment. Going inside the FM superhet, we notice that the meek little second detector has grown until it is graced by the impressive name of discriminator-detector and even has a subordinate—the limiter tube—to help it.

This last stage may be omitted with a corresponding reduction in the receiver's ability to cut out interference, but even then the problem of converting the discriminator to a circuit which can stand alone as a receiver without the preceding R.F.-I.F. system is a serious one. First let us look at

the circuits used in modern discriminator-detector systems. The two almost universal ones are shown in Fig. 1.

The circuit of Fig. 1B depends for its operation on a series of phase relationships and resulting voltages in different parts of the circuit. It is therefore very difficult to adapt to any kind of regenerating system such as must be used to get a satisfactory single-tube receiver on the U.H.F. The circuit of Fig. 1A, however, operates on a very simple principle and therefore (in spite of the fact that its more complicated coil construction has caused it to become less and less popular as a second detector in FM superhets) affords the experimenter the opportunity he needs.

If we study this circuit for a bit we find that it really consists of two ordinary AM diode half-wave detectors. Each detector uses one diode unit of the 6H6 in conjunction with the respective tuned circuit *x* or *y* and the respective 100,000-ohm load resistor.

These two diode detectors are driven from the same source and have their outputs connected in reverse series—that is, the two detectors are interconnected in such a way that their outputs are in series, but in series so that the two outputs oppose each other and tend to cancel instead of helping each other. Now let us make some curves by plotting input frequency against output voltage on each diode separately and then on the whole system. These curves are shown in Fig. 2.

In Fig. 2A are shown the curves of each half wave detector operating alone. A regular selectivity curve appears in each case, the only difference being that one is positive and the other is negative. This is because one rectifier uses as the "low" side of its output the opposite side from the one used by the other rectifier. Now let us drive both detectors from the same source and tune one so that its resonant frequency approaches that of the other until the two curves just barely overlap. We have the output curve of Fig. 2B for the complete system. The slight overlap of the two waves is used to straighten out the curved portion at the base of the waves by cancellation so that the wave will be as near a

straight line as possible between points OP-OP.

It will now be noted that the section of the curve between these points is in the form of a good discriminator characteristic. If an FM transmitter is now tuned so that its resting (unmodulated) frequency is that marked "operating frequency" in Fig. 2B and then frequency-modulated so that the sweep lies between the limits OP-OP, the discriminator-detector will give out the modulating signal with a very high degree of fidelity.

Now that we have seen the operation of this circuit, let us return to the fundamental elements of the system. These, we found, were two AM half-wave diode detectors driven from the same R.F. source and having their outputs connected in reverse series. So we see that essentially our system consists of two AM detectors. And that gives us just what we want. It is now possible to substitute a couple of triode super-regenerative circuits for the diode detectors we have hitherto been talking about, connect their outputs in the same way and couple their tuned circuits to the same antenna. Then we have a receiver with the sensitivity of an ordinary AM superregenerative and incorporating the frequency discriminating characteristic necessary for proper reception of FM signals. Using each triode unit of a double triode tube such as the 6F8-G as a superregenerative, we find that we have achieved our goal—a one-tube super-regenerative FM receiver. The circuit of this set appears in Fig. 3, complete with an audio output tube.

Some experimenting may be necessary with the connections on the windings of the two audio transformers to make sure that the outputs from the two detectors oppose each other. It may also be necessary to provide individual regeneration controls for each detector in case the output of one proves to be appreciably greater than that of the other.

Alignment of the set is simple. Tune in an AM signal on the high end of the band, set the tuning condenser at or near minimum capacity and adjust one of the 3-30 mmfd. trimmers to bring in the signal on that detector. Adjust the trimmer accurately to give maximum output as shown by

(Continued on page 30)

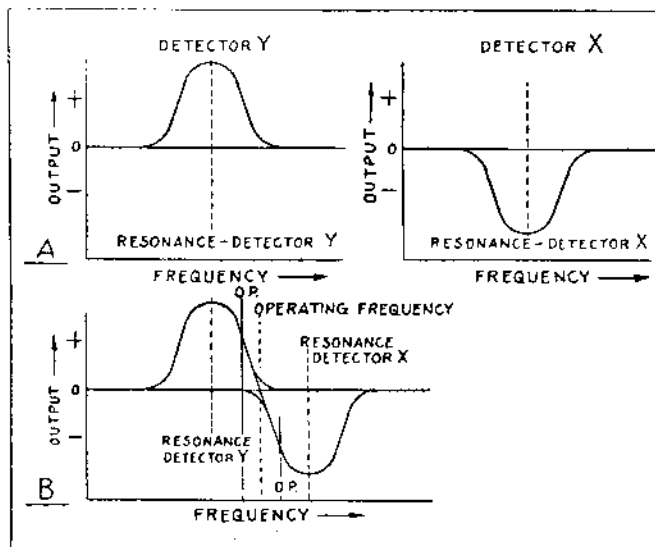
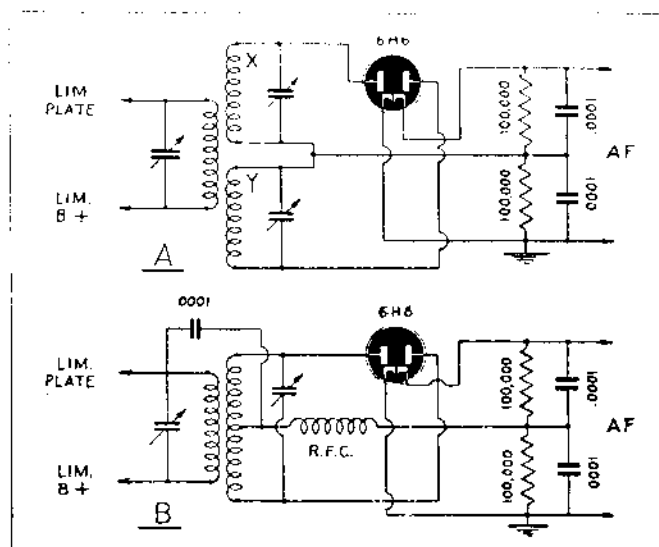

Fig. 1, left—Two fundamental FM discriminator circuits. The system at B is the one now most commonly used in commercial FM receivers. Fig. 2, right—How the two separate AM detectors of Fig. 1-A can be made to operate as a discriminator for detection of FM signals.



# WIRED RADIO IN TWO UNITS

Carrier communication has attracted a great deal of attention during the past few years. This simple equipment can be operated as an intercommunicator or used in experimenting with the various phases of "wired-wireless" transmission.

VERY good "wired wireless" results are obtainable with the simple equipment described here. I have been experimenting with these circuits for some time, using approximately 200 Kc. as carrier. Communication has been carried on a distance of 6 blocks in a crowded residential district of Berkeley, and undoubtedly greater distances are easily possible. Either phone or C.W. signals may be transmitted.

The receiver, shown in Fig. 1, uses a regenerative detector, one stage of R.F. and two stages of audio. It is built on a 7 x 7 x 2 chassis in a plywood cabinet with Masonite interior panel.

The receiver has sufficient sensitivity, considering the high static level of the power lines. High selectivity is obtained when it is in an almost-regenerating state. The tuning is broad when non-regenerating. The R.F. stage minimizes trouble due to frequency shifting as a result of ever-changing load on the power lines.

During periods of transmission, the receiver is silenced by throwing the switch from "receive" to "stand by." This switch is mounted on the regeneration potentiometer. The coil L1 is 5 turns of No. 24 to 30 wire, simply scramble-wound on a temporary paper or glass tube, just big enough to fit over the pies on the 2.5-MH choke. All other coil constants are given in the diagram. The turns of L1 are cemented together and then slipped over L2, its position being changed until best results are obtained.

A transmitter for both C.W. and phone is drawn in Fig. 2. B is a 6.3-volt bulb used as an R.F. indicator. It is fed from a single turn around the tank coil. The center tap on the tank is adjusted for maximum brilliancy of the bulb. "Ch" is a 100 M.A.

The carrier current receiver in its plywood case. The scale is marked for reception of other "stations" on the line-radio circuit.

modulation choke. If an audio amplifier is already available, Fig. 3 may be used. The regular output transformer is connected to terminals "A.F." to feed the large output transformer T1 in the figure. A modulation transformer or large class-B audio unit should be used in this circuit, as the cur-

ping it in melted paraffine wax. Coil L3 is made by winding 2½ inches of No. 20 wire on the salt box, tapping every 5 turns. L1 is 4 or 5 turns of hook-up wire wound on top of L3 so that it can be varied to suit line conditions. L2 is one turn around the form just below L3, and is the indicator



Fig. 2—The 6L6 modulator and transmitter circuit complete. Fig. 3—A suitable hook-up for use if an audio amplifier is available as modulator. Values for all coils are supplied in the article.

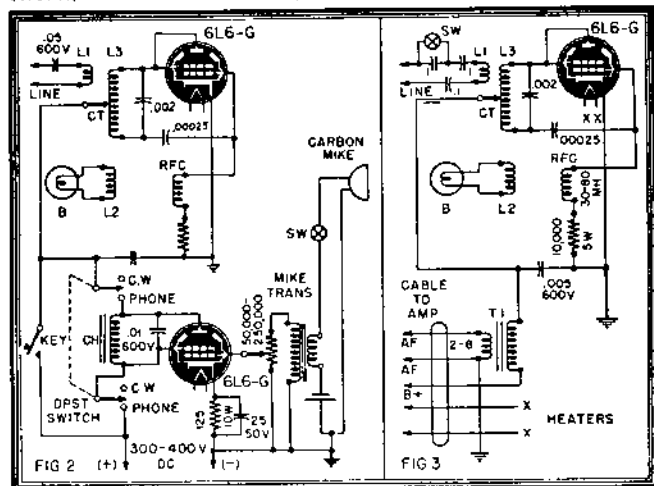

rents are very heavy, and the bigger your transformer is the better.

Coils for either transmitter may be wound on a 3¼-inch diameter coil form (salt box). If an actual salt box is used, be sure to moisture-proof it with a couple of coats of insulating varnish, or by dip-

light circuit for tank tuning adjustment.

The circuit may be adjusted for greatest brightness of the indicator lamp with the line not coupled to it. Then the center-tap of L<sub>1</sub> is moved a turn or two toward the plate end of the coil. This will reduce apparent power, slightly, with notable increase in stability and quality of speech transmitted.

Choice of frequency is an important point in the operation of any transmitter working over light or power lines. Changing the frequency only a few kilocycles may make a tremendous difference in the amount of power that can be put into the line.

The indicator will show whether a normal amount of power is being taken. If the lamp burns at full brilliance when the line is coupled, little power is being transferred. If it goes out entirely, probably too much is being absorbed.

All the circuits shown are straight forward and used standard parts, many of which may be found in the junk-box. I am very pleased with my carrier current results and hope some of you experimenters will join me.

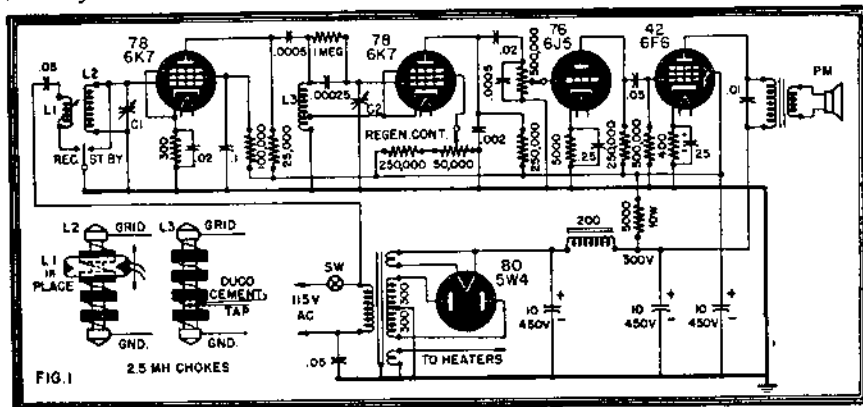
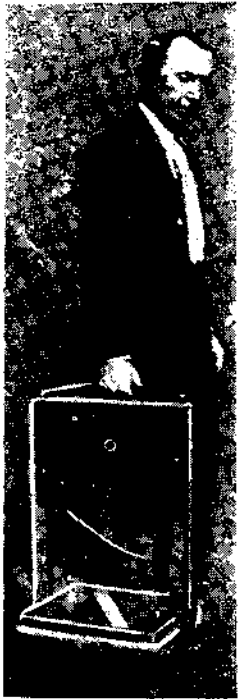

Fig. 1—Coils for the 200-kc. receiver are constructed from 2.5-millihenry R.F. chokes.



# 1-Tube Metal Locator

This Smallest Treasure Locator is Compact, Simple and Reasonably Sensitive.

This locator is easier to carry through rough or wooded country than larger but more sensitive metal locators.

A short while ago I finished building a very compact treasure-finder which for a small-size job is unusually sensitive for metal detection. Really good results have been obtained with it. The schematic is shown and the photo gives an idea of physical size. Incidentally, there is plenty of room in the cabinet, which was used because it happened to be available.

The 3A8 GT requires only .1 amps at 1.4 volts when its filaments are wired in parallel as it is in this case. The total drain on the "B" battery is less than a milliamperere, so that the drain on the pocketbook is also small. There is room for improvement in this circuit so I am passing it along to you experimenters. I believe it would make an easy outfit for the beginners in this field. The circuit is self-explanatory.

I have now started to experiment with

an even more compact treasure device which will use two or three tubes and which, I hope, will be the utmost in sensitivity. It requires but 45 volts of "B" battery. Possibly I may have the circuit and details as well as results available for *Radio-Craft* readers in the near future.

In conclusion let me state as a veteran in this field that exploring for metal is fun and can be profitable, too. Here's luck to you!

### Bibliography

- RADIO NEWS, Sept., 1932—May, 1933.
- RADIO-CRAFT, June, 1931—July, 1933—Aug., 1934—Aug., 1935—Aug., 1936—Oct., 1935—Sept., 1939—Dec., 1940—April, 1943.
- SHORT WAVE RADIO, May, 1937
- RADIO & TELEVISION, Mar., 1939—Mar., 1941.
- POPULAR MECHANICS, Oct., Nov., 1937.
- SCIENCE & MECHANICS, Feb., 1939.
- RADIO WORLD, JAN., 1938.

**T**HE writer has been building and using treasure locators with gratifying results for some 20 years. I have experimented with large and small outfits during this period, have used simple and complicated circuits, and can state that any good locator, properly designed and constructed, will give good results in the location of buried metal. As tubes, circuits and components improve in quality, better results become obtainable with less difficulty.

My first treasure locator used the buzzer system. This was ultra-modern at the time and the circuit was one of the latest and great sensitivity was claimed for it. The exploring coil consisted of 500 turns wound 24" by 48", a lot of wire even with no shortage! However, it was required at that time.

After making all connections a friend and I tried out the gadget. For hours we strained at the phones but were able to hear only a constant, weak buzz. Finally there was nothing to do but give up in disgust, with a very low opinion of locators in general and this one in particular. We tried again a few times on other occasions and finally hid the whole locator where it would be out of sight and mind.

About a year later there arose an occasion when I suddenly required some length of wire for some experiment (not in connection with locators) but found that I had none on hand. I then remembered the exploring coil with its mile of wire. I started to unwind the loop and couldn't help feeling that the locator had come in handy after all. What a break! What? A break? Sure enough, about half way down the coil the wire had parted in such a way as to remain unnoticed! This episode may partly account for the fact that I am now known as quite expert in the use of all methods of continuity testing.

To get back to proper construction, the best locators I have ever built were the ones described by Mr. G. M. Bettis in the Feb., 1940 *Radio & Television*, and in the April, 1943, *Radio-Craft*. A number of other excellent circuits are outlined at the conclusion of this article. These are sensitive circuits and will give practical results.

The one-tube treasure locator L1, L2 is an ordinary plug-in coil tunable to 1700 Kc. L. exploring coil 24" x 24" x 4". It is wound with 14 turns of No. 14 wire. C1, C2 — 65-350 mmfd. padders. C3, 3-30 mmfd. trimmer used with short 1- or 2-foot aerial.

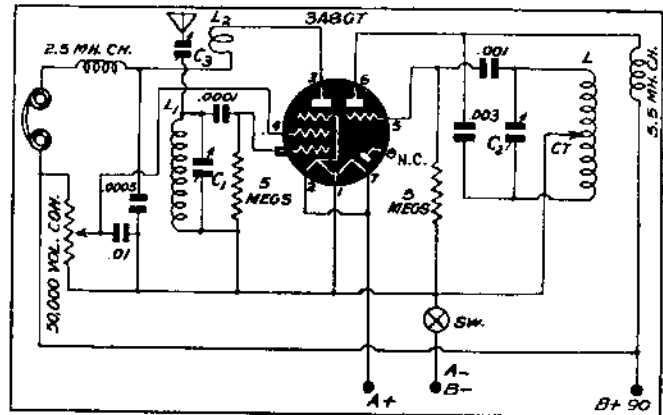

## TWO-TUBE FM RECEIVER

(Continued from page 28)

an output meter, indicating that the signal is tuned in exactly. Then tune the other trimmer until the signal is received on the other detector. This will be indicated by the meter reading falling to 0 or to a minimum very near 0. The trimmer should then be backed off until the meter just returns to the peak previously shown by it. The receiver will now receive FM signals. To

bring it to peak efficiency, the FM transmitter already described should be modulated with a constant audio tone and the signal picked up on the receiver and tuned in for maximum output. The last trimmer mentioned above may then be adjusted to give maximum output and fidelity. This may be done by ear, or with an output meter.

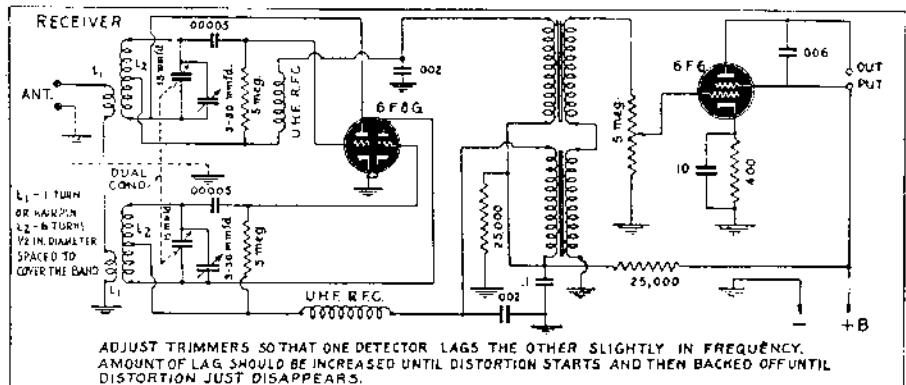

ADJUST TRIMMERS SO THAT ONE DETECTOR LAGS THE OTHER SLIGHTLY IN FREQUENCY. AMOUNT OF LAG SHOULD BE INCREASED UNTIL DISTORTION STARTS AND THEN BACKED OFF UNTIL DISTORTION JUST DISAPPEARS.

Fig. 3—Complete diagram of the 2-tube FM receiver, with 1-stage audio for headphones.

# Cross-Over Networks

**B**ECAUSE of the difficulty of designing a loud-speaker which will function efficiently over a wide frequency range, it has been common practice in FM radios and movie sound work to use a "woofer" for the lower frequencies and a "tweeter" for the highs. The tweeter is generally a low-power unit since the high frequency sound energy is small in comparison with the low. The woofer is a rugged, heavy-duty unit. The job of dividing the electrical energy into two paths falls to the dividing network. A simple type of network is shown in Fig. 1. R is the voice coil resistance or speaker resistance in ohm, C is the capacity in farads and  $f_c$  is the crossover frequency in cycles. L is the inductance in henries.

The circuit action is easy to visualize. A condenser is connected in series with the high-frequency speaker. Since condenser reactance decreases as frequency rises more high frequency current gets through to the tweeter than low frequency current, thus favoring the highs so far as the tweeter is concerned. Also note that in Fig. 1 a coil is connected across the high frequency speaker terminals. Thus the shunt current through the coil will be greater at the lower frequencies, since the coil has low reactance at these frequencies. As the frequency rises the coil current is decreased and the current in the high-frequency speaker rises. The opposite action occurs so far as the low frequency or woofer speaker is concerned. It has a condenser in parallel with it. The shunt reactance of the condenser decreases as the frequency is raised, shunting away an ever greater amount of current from the woofer at higher and higher frequencies.

Still another form of dividing network is shown in Fig. 2. The action here is somewhat the same as in Fig. 1, but note that as  $X_c$  decreases not only is there less opposition to the flow of high frequency signal current in the tweeter, but also an increased shunting of high frequency current away from the woofer—through the condenser and tweeter. The choke coil L opposes the high frequency current but offers relatively little opposition to the lower frequencies. Note that, looking into the input terminals of this network at a particular frequency, we may run into parallel resonance. At such a frequency the load on the source connected to the input will drop and the output voltage of the source will rise, which may cause feedback and oscillation in an amplifier system. The damping action of the speaker resistances, however, would tend to decrease the Q of the resonant circuit and to give a broad peak, so that in all probability the resonant build-up would be so small as to call for no design features to overcome it.

The type of network shown in Fig. 3 is sometimes used. The C and L values are equal. This circuit is somewhat similar to the basic type in Fig. 1, but here we have added capacitive and inductive elements in series with tweeter and woofer, thus enhancing the sharpness of cross-over and the frequency discriminating properties of the complex network. The basic action remains the same, series inductance cutting down the highs and favoring lows, series capacitance highs, shunt capacitance cutting highs, shunt inductance raising highs.

Another form of network is shown in

Fig. 4. It is apparent that here the series combination of L and C across the input may resonate at a definite frequency. When that happens, the voltage across the coil in shunt with the tweeter will rise to a peak value which may be undesirable. Hills and valleys in the response of the speakers are not wanted, but a flat response is often desired. A great deal depends on other design factors. For example, if the speaker cabinet is of such design that the lows are not properly reproduced the peak may be permissible or even desirable in the case of the woofer and the series resonant circuit associated with it. An expansion of this network, quite simple in nature, involves adding an additional inductive element, as indicated in Fig. 5. An additional capacitive element is added in series with the tweeter.

The division of frequencies is not complicated nor difficult to arrive at, but from a practical viewpoint there may be complications in properly distributing the power. If too much power is fed to a tweeter it will overload.

A circuit that can be used on a practical basis is that of Fig. 6. Considerable flexibility is afforded by the design. The amount of power fed to the speakers can be controlled by selection of the turns ratios on the transformers. (See "Matching Loudspeakers.") Further, in the case of the tweeter, the power can be controlled by selection of the series capacitive element C5 if necessary. Usually, C5 is made large enough so that it offers little opposition to high frequency currents and the amount of tweeter power is then controlled by T2 and C6.

References:  
 RADIO ENGINEER'S HANDBOOK, Terman, 1st ed., p. 249.  
 LOUSPEAKER DIVIDING NETWORKS, Hil-

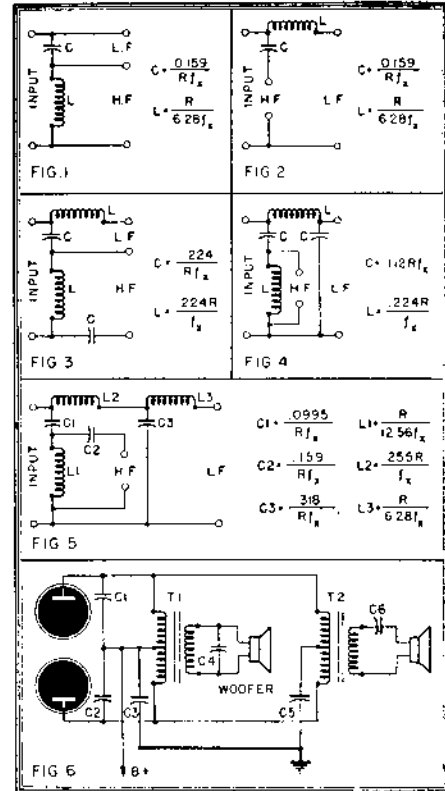

Several loudspeaker cross-over systems. Fig. 6, bottom, is a highly practical, flexible circuit.

liard, *Electronics*, January 1941, p. 26.  
 DIVIDING NETWORKS FOR TWO WAY HORN SYSTEMS, *Communications*, June 1942, p. 14.

## ULTRA RADIO

(Continued from page 19)

recommends the use of a 15 inch antenna. The characteristic superregenerative hiss will be present on all frequencies if the receiver is oscillating properly. When a station is tuned in the hissing sound fades into the background, thus a lack of hiss

within the oscillating band will usually indicate a station. Code wireless stations may be rather hard to read, because of the silent space present when the station is sending out a dot or dash, and the hiss sound present when the station is not sending.

CL1 TAPS	COIL	CL2	CL3	Approximate Wavelength
0	A	2½ turns spaced No. 20 wire	3¾ turns close No. 28 wire	10-18 meters
0	B	4¼ turns spaced No. 28 wire	4½ turns close No. 28 wire	16-21 meters
0	C	4¼ turns close No. 28 wire	4¼ turns close No. 28 wire	19-24 meters
0-1	D	4¼ turns close No. 28 wire	7½ turns close No. 36 wire	23-35 meters
0-4	E	5¼ turns close No. 28 wire	11½ turns close No. 36 wire	35-75 meters
0-6	F	7¼ turns close No. 28 wire	21 turns close No. 36 wire	75-120 meters

but it is essential to good recording. It seems that it "loosens up" the wire magnetically, thus permitting the signal to be impressed on it.

As previously stated, when recording the output of the amplifier is fed through the No. 1 secondary of the oscillator to the recording head and then to the ground. The selector switch opens the oscillator cathode connection to ground when the machine is used to play back or reproduce.

The next step is the construction and selection of parts for the recording head. Here each individual must use his imagination and ingenuity. I have constructed about 12 heads. Each one used a different coil in either physical size, shape, number of turns, or D.C. resistance. Therefore I will describe the construction of only one, the one that has worked best.

All the heads worked but differed mainly in recording. The coil I used came from an old Atwater Kent magnetic speaker, the D.C. resistance measuring 700 ohms. The physical dimensions were  $\frac{3}{4}$  by  $\frac{25}{32}$  by  $\frac{1}{2}$  inches. The core was  $\frac{3}{16}$  by  $\frac{5}{16}$ . Refer to Fig. 2 for the shape and manner of assembling. I have found that almost any coil will work as long as the gap in the core is kept between .001 to .003 inches. I used a piece of brass shim stock to maintain the gap at .002. I used a jeweler's hack saw with the finest blade obtainable to cut the slot for the wire to run through. After filing the core to shape, I assembled the pieces without putting them on the coil. I had them clamped together to enable me to drill the holes for 2-56 screws. Then I put the pieces on a wire, being careful to observe the order in which they were assembled so they may be reassembled in the

## A MAGNETIC RECORDER

(Continued from page 6)

on the drive shaft. The two wire-pulling drums I used were about 5 inches in diameter with a rim on each side to keep the wire from running off. I used microphone cable to connect the recording head and erase coil to the amplifier-oscillator assembly. A word of caution here in regard to running the wire puller; use your hand as a brake when stopping the reels! The wire may become hopelessly snarled if the reels are allowed to coast after the power is turned off. I rewind the wire by hand. Incidentally, when recording or reproducing the wire should move through the head at a constant speed of about 180 feet per minute. Whatever your speed is (it will work at slower speeds but not so well) it must be constant all the time.

You will have to find by trial and error how high to run the volume control and the audio filters when recording. Each set will vary, of course. If the reproduction sounds too bass and garbled it indicates you haven't filtered out the low frequencies enough. By connecting a pair of earphones across a small coil similar to the one used in the recording head and held close to the recording head you can monitor the record continuously.

Before you have taken the "bugs" out you will have broken your recording wire many times, unless you're exceptionally fortunate—and I've never yet met a radio ham that lucky. So remember this suggestion:

- R17—200 ohms 10 W
- R18—30m ohms
- R19—30m ohms
- R20—100m ohms v.c.
- R21—20m ohms—10 W
- R22—25m ohms
- R23—500m ohms
- All resistors  $\frac{1}{2}$  W unless otherwise stated.
- C1—20 mfd.—30v
- C2—.05 mfd. 600v
- C3, 5, 12, 21—.06 600v
- C4, 11, 13—.20 mfd. 50v
- C7, 10—.25 mfd 600v
- C8, 9—.006 600v
- C14—.25 mfd. 600v
- C15, 16—.8 mfd. 450v
- C17, 18—.30 mfd. 450v
- C19—.0005 mfd. 450v
- C20, 22—.01 mfd. mica
- C23—.03 mfd. 600v
- CH1, 2—.125 m.h.
- CH3—Filter Choke
- L1—Oscillator coil
- L2—No. 1 secondary
- L3—No. 2 secondary
- L4—Erase coil
- L5—Recording and reproducing head
- S. R. 6-pole double-throw switch

## ECONOMY 20-WATT

(Continued from page 13)

front, the very slight mismatch being of no importance and not detectable by ear. If a dynamic type of speaker must be used, a 750-ohm field can be substituted for the filter choke with a reduction in power output to about 15 watts. At full volume, the field energization is about 8 watts so the magnetic circuit must be of high efficiency. Suitable Australian speakers are the Amplion TO75, a 10-inch heavy duty dynamic with a  $1\frac{1}{2}$ -inch voice coil, or a Magnavox 182. Suggested American speakers are the Jensen A15PM, the Lafayette P12G or the Utah G12P.

A very low hum level is obtained for several reasons. All earth returns are made to a busbar consisting of a strip of copper  $\frac{1}{4}$ -inch wide, this being connected to the metal chassis at one point only -- just near the No. 1 terminal of the first 6SC7. Small shields of tin-plate are soldered to the chassis in appropriate places to electrostatically screen the .5 megohm mixing resistors, the anode resistors of the first tube and the pick-up bass-boost network. The input connections are made by means of UX and UZ tube sockets and these, too, are shielded.

The filament wiring is connected to a simple voltage divider, thereby being about 35 volts positive with respect to the chassis, and therefore making the grids about 35 volts negative with respect to the filaments, thus preventing filament emission.

A final reduction in hum is, of course, obtained from the negative feedback.

The *phono pick-up* is a four-pole needle-armature type with an output of about .4 volt. It has negligible bass boost owing to the mass of the head being large, hence the boosting network. Although the pick-up head is heavy, a counter-balance reduces the thrust on the record to about 1 ounce, only a small thrust being needed on account of low needle point impedance.

The *microphone* generally employed is either an Australian version of the D104 or a Shure model 9822A. Sometimes a semi-directional floating-cone dynamic microphone is used when wide-range music is to be amplified. The amplifier is not suited for use with sound-cell mikes or low-level dynamics.

The tone and volume of this amplifier are surprisingly good, the freedom from unpleasant distortion enabling the speakers to be placed close to the audience without exciting rude remarks.

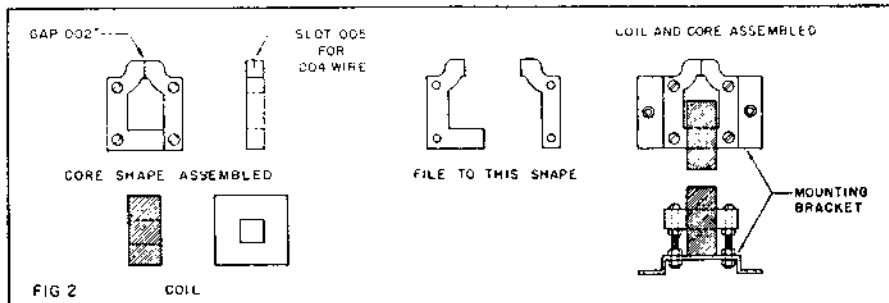

exact way they were when the holes were drilled. With the wire strung out so the individual laminations were well separated I then heated them red hot with a blow torch and then left them to cool gradually.

I have also tried cooling them in an A.C. magnetic field—using an old speaker field for the purpose—and I believe this improved the efficiency of the core. After cooling, I assembled the laminations on the coil. Hold this together with 2-56 brass screws and nuts. Before tightening dip the whole thing in dipping varnish, tighten and allow to dry.

Next get a small piece of phenolic tubing  $\frac{1}{8}$ -inch diameter or some similar material, to wind the erase coil L4 on. The wire will be passed through this coil to clean it magnetically so it will be ready for another recording. I used No. 28 enamel wire although I do not believe the size or number of turns to be critical. The tubing was about  $1\frac{1}{2}$  inches long and the coil on the tube about one inch long, layer wound about 200 turns. I mounted this between two pieces of  $\frac{1}{4}$ -inch bakelite with holes drilled for a close fit so the tubing fits into the holes in the bakelite ends. Cement the coil in place with ordinary coil cement.

We are now ready to assemble the wire puller, head, and erase coil. I mounted the motor below the panel with an extension

when the wire breaks anneal the ends with a match flame, the heat from a cigarette, or bring out a tap from a filament supply and hold the wire across the voltage until it changes color. Then tie the ends together with a square knot and cut the surplus ends off. Apply a little more heat after tying the wire. The very small steel wire will burn if a match is held too close to wire, so be reasonably careful.

I installed a neon bulb as a volume level indicator as shown on the schematic. The point at which this bulb will flash can be controlled by R-20. R-20 should be adjusted so the bulb flashes just on the amplitude peaks.

And now that you know how to build it just dig into that "junk box" of radio parts over in the corner and you will find the makings of the magnetic wire recorder.

### Parts List

- R1—.2 meg.
- R2—800 ohms
- R3—.2 meg.
- R4—500m ohms
- R5—500m ohms v.c.
- R6—2m ohms
- R7—1 meg.
- R8—250m ohms
- R9, 10, 11, 12—4m ohms—2 W
- R13—250m ohms
- R14—850m ohms—2 W
- R15—30m ohms—2 W
- R16—30m ohms

**MAKE MORE MONEY**

# Radio TELEVISION & ELECTRONICS

**GET THESE 2 BIG BOOKS**

**FREE!**

You men already in Radio know how great the demand is for trained, experienced servicemen, operators and technicians. You know how fast the field is growing and how important it is to keep up with developments — P.M. Receivers, Electronics and Television. You know, too, a fellow cannot learn too much about any industry for **REAL SUCCESS**. Whether you have experience or are merely **INTERESTED** in radio as an amateur, you must recognize the **WONDERFUL OPPORTUNITY** right within your grasp to cash in on your natural abilities. Make them pay dividends. Get into the **EXPERT RADIO SERVICE FIELD**. Be an F.M. and **TELEVISION** specialist—**OWN A BUSINESS OF YOUR OWN**, if you prefer. Fill out and mail the coupon below for all the details of our plan.

Here's Just a Few of the Interesting Facts you Learn with the **FREE MANUAL**.

1. Routine for diagnosing Radio Troubles.
2. Preliminary Inspection of Receivers.
3. How to Check Power Supply.
4. How to Identify Various Stages of Receiver.
5. How to Trace the Circuit and Prepare Skeleton Diagram.
6. How to Test and Measure Voltages.
7. How to Test Speaker in Audio Stages.
8. How to Test Detector, I.F., R.F., and Mixer Stages.
9. Complete Reference Table for Quickly Locating Receiver Troubles.

Get the Latest Inside Information—Short Cuts—Trade Secrets by



## SHOP METHOD HOME TRAINING

**FROM A REAL ESTABLISHED RESIDENT SCHOOL**  
Now the famous National Schools brings its exclusive Shop-Method of training right into your own home. You can learn the most up-to-date, approved projects, systems and circuits step by step in your spare time. This is the sound practical training you want and need—the development of experienced instructors working with thousands of students right in shops, **NEW F.M.** broadcast studios and experimental laboratories of **NATIONAL SCHOOLS**—one of the most advanced trade educational centers in the world.



### LEARN BY DOING

Work with Real Experimental Equipment Furnished without Extra Cost as Part of Your National Training

*Experience is the best teacher.* You learn by experience with the exclusive National Shop-Method of Home Training. In the course of your study you actually build various types of receivers—a powerful superheterodyne, a signal generator, an audio oscillator and others—you make tests and conduct experiments that *show you the why and how of things.* You understand what makes the various elements of electronics operate because you actually see them work for you. Not only do you gain marvelous experience by this method of learning but you receive valuable equipment you will use on the job in the practice of your profession as an electronics expert. *Mail the coupon and learn what this means to you.*

Send the Coupon and prove to yourself what YOU can do in RADIO!

### National Trained Men Now Making the Best Money in History

The real value of National training shows up on the quick progress our men make on the job. Incomes that seemed fantastic only a short time ago are now being reported by National graduates. And this is only a sample of what the future holds for the **MAN WHO KNOWS RADIO, ELECTRONICS, F.M., TELEVISION** and allied subjects. National is proud of the progress its graduates are making all over the world. Read the facts—the actual proof in the books we send you **FREE**.

### Be Sure Of Your Success And Security After The War

Don't let your post-war ambitions lag. Don't let YOUR future depend on others. Build a career for yourself. Never in all history has the returning serviceman, or war worker been confronted with such a great future if he reaches out and grasps it **NOW**. Here is a new world opening before you. Get ready now while you are still in uniform while you are on your war job. Then you can cash in on an essential, well paid position or, with little capital, **GET INTO BUSINESS FOR YOURSELF**. It isn't a bit too soon to start now. Radio men are vitally needed. Fill out and mail the coupon immediately and examine the **NATIONAL SHOP METHOD HOME TRAINING COURSE** carefully, without obligation.

### FREE LESSON INCLUDED

Examine the exclusive National Shop Method of Home Training. See for yourself how sound and practical it is. Be convinced that you can learn Radio, Electronics, Television—quickly and easily in your spare time. You can't tell until you try. This trial is **ABSOLUTELY FREE**. Fill out the coupon immediately while you are thinking about it and drop it in the mail at once.  
Mail the coupon here for the books that tell you the complete story of the marvelous new system of training in Radio, Electronics and Television. Learn the facts of this exclusive shop-method of home training. See for yourself **DECIDE FOR YOURSELF!**  
This is the **MODERN SYSTEM OF TRAINING**: it matches the rapid progress constantly being made in Radio, Television and Electronics. It is **TIME TESTED**, too. National Schools has been training men for more than a third of a century. It is the very same training that has proved the most successful in every way and greater opportunity.  
You owe it to yourself—your future—to read the book "Your Future in Radio, Electronics and Television"—**FREE** to you when you send in the coupon.

## NATIONAL SCHOOLS

LOS ANGELES 37, CALIFORNIA EST. 1905



### MAIL OPPORTUNITY COUPON FOR QUICK ACTION

National Schools, Dept. **REA**

(Mail in envelope or paste on penny post card)

4000 South Figueroa Street, Los Angeles 37, California.

Mail me **FREE** the two books mentioned in your ad, including a sample lesson of your course. I understand no salesman will call on me.

NAME ..... AGE .....

ADDRESS .....

CITY ..... STATE .....

# MATHEMATICS FOR RADIO AND COMMUNICATION

by GEORGE F. MAEDEL, A.B., E.E.  
Chief Instructor, R.C.A. Institutes

Here are the books that every man interested in the technical phases of radio will want to have. They have been written especially for students in school, and at home, to prepare them to read technical books and magazine articles on radio. The author is Chief Instructor of R.C.A. Institutes, and his books are official texts on mathematics in that well-known school.

## BOOK I

(314 pages)

covers the subjects: Algebra; Geometry; and Arithmetic.

The chapters are: Addition, Subtraction, Multiplication, and Division in Arithmetic; Definitions and Symbols; Involutions and Evolution in Arithmetic; The order of Operations in Arithmetic and Algebra; Fractions in Arithmetic; Definitions and Notations in Algebra; Axioms; Positive and Negative Numbers; Addition, Subtraction, Multiplication, and Division in Algebra; First Degree Algebraic Equations; Exponents and Radicals in Algebra; Standard Products and Quotients; Factoring; Common Factors and Multiples; Fractions in Algebra; First Degree Fractional Equations; Decimals and Powers of Ten; The Metric System; Engineering Problems and the Slide Rule; Quadratic and Radical Equations; Simultaneous Simple Equations; Postulates; Definitions of Geometric Quantities; Rectilinear Figures; Circles; Loci; Similar Figures; Areas; Measurement of the Circle; Constructions; Coordinates; Solid Geometry; Formulas Used in Geometry. ANSWERS to the problems are given.

## BOOK II

covers the subjects: Advanced Algebra; Trigonometry; and Complex Numbers.  
(329 pages)

The chapters are: Algebraic Formulas; Numbers and Precision of Measurements; Graphs; Logarithms and Decibels; Trigonometric Functions of Acute Angles; The Right Triangle and its Applications; Trigonometric Functions of Any Angle; Graphs of Functions and Their Engineering Use; Functions of Combined Angles; Trigonometric Equations and Identities; Oblique Triangles; Ratio Proportion and Variation; Determinants; Simultaneous Quadratic Equations; The Binomial Theorem; Progressions and Series; Complex Numbers. ANSWERS to the problems are given.

### CLIP COUPON AND MAIL

MAEDEL PUBLISHING HOUSE Room 117  
593 East 38 Street, Brooklyn, New York

Send me MATHEMATICS FOR RADIO AND COMMUNICATION as checked below. I enclose payment therefor with the understanding that I may return the book (s) within 5 days in good condition and my money will be refunded.

Name .....

Address .....

Address .....

- Book I at \$3.75 plus 6c postage  
 Book II at \$4.00 plus 6c postage  
 Books I and II at \$7.75 postage prepaid  
 Foreign and Canadian prices 25c per volume higher.

## CAPACITESTER

(Continued from page 14)

A.C. switch on the lower left and the locking switch on the lower right. The pin tip jacks are mounted one pair on each side. The oscillator and radio frequency amplifier coils are ordinary solenoid broadcast coils with the primary windings removed. The oscillator coil is tapped two-thirds of the way down from the grid end for the cathode connection. Two holes were drilled in each coil form, an eighth of an inch apart and a quarter inch below the bottom of the winding. A single turn of hookup wire was wound here and cemented in place, with the ends threaded through the holes and leading out the bottom of the coil form and shield can in which each coil is mounted. A 15 mmfd. mica trimmer condenser is connected across each of the larger windings and a hole drilled in each shield can opposite the trimmer screw to permit the coils being tuned to the same frequency. A screwdriver is used for the tuning.

The frequency used does not have to be exactly 1800 kilocycles; any frequency near this will be satisfactory, preferably the highest one to which both coils will tune accurately. The two shield cans containing the coils are mounted under the chassis three inches apart and the link coupling turn leads are fastened in place by means of tie points. The constructor can place the rest of the parts to suit himself, providing the oscillator and the tuned circuit are so arranged there will be no interaction with the link coupling circuit open.

On the opposite side of the link circuit connected to the pin tip jacks, the circuit is again broken and a one tenth mfd. condenser inserted. This enables continuity or voltage tests across the condenser being tested simultaneously with the quality test. A small condenser is connected from one side of the pin-jack circuit to ground. This prevents any radio frequency pickup due to capacity between the larger winding and the link coupling turn. This tip-jack should be marked and used as the ground potential side of the test leads. The link coupling circuit is isolated from ground except for this small condenser so voltage or continuity checks can be made across the condenser under test or from either side of it to ground.

To place the unit in operation, allow the tubes to heat for about 15 minutes. Connect a jumper across the pin-tip jacks or clip the test leads together, making sure the locking switch is in the (off) position. Advance the gain control until the indicator tube shadow starts closing. Accurately tune the oscillator and radio frequency amplifier circuit by means of the screwdriver trimmer condensers to the highest frequency to which both will respond. This peak will be indicated by the degree of closing of the indicator tube shadow. The process will have to be repeated several times, reducing the gain control each time the indicator tube shadow closes completely until the point of sharpest tuning is obtained.

When this is reached the testing portion of the instrument is complete. Now adjust the locking circuit as follows: With the link coupling circuit still closed advance the gain control until the indicator tube shadow just comes together. Close the locking switch; if the indicator tube shadow opens it indicates too much plate voltage on the 6F5 tube. This will have to be reduced until closing the switch has no effect on the indicator tube. This can be done by

placing a small load on the secondary of the audio transformer by means of resistors placed across it or by a potentiometer across the A.C. line with the primary of the audio transformer connected to one side of the A.C. line and the center tap of the potentiometer. Whichever method is used, adjust the voltage until closing the locking switch no longer affects the indicator tube. When this point is reached, open the link coupling circuit momentarily and then close it again. If the unit is wired correctly the indicator tube shadow will open and remain so indefinitely until the locking switch is turned off.

There are only two controls, the R.F. amplifier gain control and the locking switch. Heat the tubes to operating temperature, hold the test prods together and adjust the gain control until the indicator tube's shadow just closes. Plug an ohmmeter or voltmeter, depending on whichever method you prefer, in the two extra pin-tip jacks provided for this purpose and proceed to check the condensers in their circuit, remembering to use the prod so marked on the ground potential end of the circuit. An open condenser will be indicated by the indicator tube's shadow refusing to close completely and in most cases by refusing to move at all. The operator of this unit can familiarize himself with its operation by making tests of combinations of various sized resistors and condensers in parallel, noticing the shadow positions with the condenser in and out of the circuit.

If a condenser is suspected to be intermittent the test leads should be clipped across it and the condenser squeezed with the fingers or tapped with a rubber tube tapper or similar instrument. If the condenser makes and breaks contact due to this treatment it will be shown by the indicator tube's shadow blinking or opening. To test a condenser over a period of time, the leads are clipped across it and the locking switch closed. If the condenser open circuits at any time the locking tube will keep the indicator tube's shadow open, showing the condenser to be intermittent. A shorted or partially shorted condenser will be shown by the discrepancy of the ohmmeter or voltmeter reading in comparison with the circuit diagram or voltage chart. This makes a very handy combination; both a condenser quality check and a point-to-point resistance or voltage reading simultaneously, using the ohmmeter or voltmeter already in the shop.

In some instances it may be necessary to insert a low resistance radio frequency choke in series with the pin-tip jacks used for the meter connection, but in most cases it will be found the meter movement has enough reactance in itself that it will not move the tuning indicator shadow when connected to this instrument. This condenser tester does not indicate the capacity of electrolytic condensers. The capacity of paper and mica condensers is either marked on them or the circuit diagram, and does not vary with age or use as with the electrolytic ones. This instrument will check electrolytics for radio frequency reactance and will pick out a defective one that may be causing radio or audio feedback due to common coupling in the filter circuit. In most cases where the electrolytic condenser checks OK for capacity and is still operative in its filtering action a mica or paper condenser placed in parallel with it will cure it until a new one can be obtained.

*Simplify*

**TEST PROCEDURE**

with these versatile  
**WESTON**  
Test Instruments

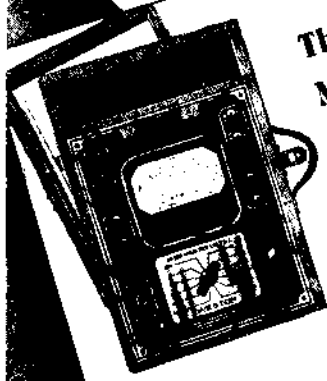

**The Multi-Purpose, Super-Sensitive Analyzer (MODEL 772)**

A compact and practical wide-purpose instrument with sensitivity of 20,000 ohms per volt, on dc ranges.

Ranges — all self-contained

Voltage, a-c and d-c — 0-1000, 250/50/10/2.5, 1/10, 50/200/500/1000 volts (20,000 Ohms per volt).

Current, d-c — 0-10/1 amps. — 0-250/50/10/1 milliamps, and 100 microamps.

Ohms — Full Scale — 30/3 megohms — 30,000/3000 ohms, Center Scale — 250,000/25,000, 250/25 ohms.

Decibels — -14 to +2, -2 to +14, +12 to +28, +26 to +42, +38 to +54.

(Voltages up to 5000 dc available through use of external WESTON Televerter, Model 766.)

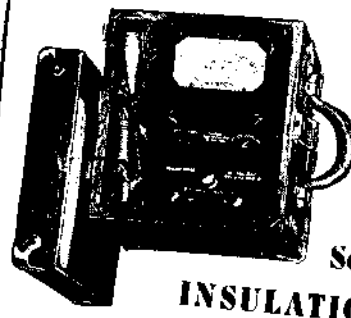

**The Direct-Reading, Self-Contained INSULATION TESTER (MODEL 796)**

This compact direct-reading resistance tester eliminates hand cranking and thus makes leakage testing a simple one-man job especially in unaccessible places. Tests up to 200 megohms at test potential of 350 to 500 volts d-c; although, the current at terminals is only a few microamperes. Operates from long life, light-weight batteries. There are no vibrators to replace.

Ranges: 0-20-300 megohms full scale; 0-5-5 megohms center scale. Size 8" x 9 1/4" x 8".

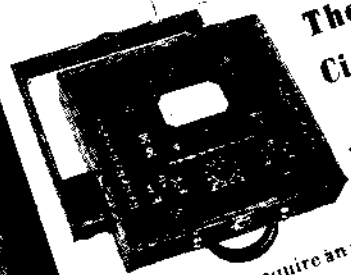

**The Industrial Circuit Tester (MODEL 785)**

Recognized as the most complete unit for routine maintenance tests, and for testing needs which require an ultra-sensitive instrument.

Ranges all self-contained

D-C VOLTAGE ... Six Full Scale Ranges of: 1/10, 50/200/500/1000 volts (20,000 Ohms per volt).

A-C VOLTAGE ... Six Full Scale Ranges of: 5/15/30/150/300/750 (1,000 Ohms per volt).

D-C CURRENT ... Six Full Scale Ranges of: 50 Microamps ... 1/10/100 Milliamps. ... 1/10 Amps. (Higher ranges, at half scale reading, with 100 mv. external shunts).

A-C CURRENT ... Four Full Scale Ranges of: 5 1/5/10 Amperes. (Higher Ranges with external current Transformers.)

RESISTANCE ... Five Full Scale Ranges of: 3,000, 30,000/300,000 Ohms ... 3/30 Megohms. Center Scale Values ... 25/250/2,500/25,000/250,000 Ohms. (Self-Contained Batteries)

With production currently running slightly ahead of war requirements, a limited number of the popular WESTON test instruments shown herewith are available and are offered subject to prior sale. Orders can be placed direct, or with the WESTON representative in your vicinity. Literature available from...WESTON Electrical Instrument Corporation, 599 Frelinghuysen Avenue, Newark 5, New Jersey.

**WESTON INSTRUMENTS**

# A COMPACT AMPLIFIER

**T**HE amplifier here has excellent fidelity when used with a well-baffled 10-inch speaker. It is shown removed from its cabinet, where it has of late been in use as a small phono sound system.

The two knobs on the front are volume and tone controls. Above them may be seen the input jack and indicator jewel. The input lead, as shown, is short and well-shielded to avoid hum pickup.

The chassis base, 7x4½x2 inches, was taken from an old kit, as were some of the other parts. The speaker field acts as one of the filter chokes.

This set may be used as a phone amplifier; with one of the new medium-output dynamic or crystal mikes; or as a small set amplifier. I have used it to supply the "B" and heater voltages as well, when working with small receivers.

The amplifier is the result of considerable experimentation in circuit and design in an attempt to build an economical but efficient amplifier. Metal tubes were available, so they were used, but of course their G or GT equivalent may be used. The power supply is quite conventional, and built large enough to supply extra power for equipment associated with the amplifier. Any of the usual rectifier tubes might be substituted for the 5Z4, with an accompanying change in circuit design if necessary. Following is the parts list:

## RESISTORS

- R1—1000 ohm 1 watt resistor
- R2—9000 ohms, 2 watts
- R3—250,000 ohm ½ watt resistor
- R4—100,000 ohm 1 watt resistor
- R5—250,000 ohm tone control
- L1—Speaker Field
- L2—10-Henry choke

This neat and versatile unit is conservatively rated at four watts. If it is carefully built of excellent materials, it is capable of good work in many small-amplifier applications

- R6—450 ohm 1 watt resistor
- R7—500,000 ohm volume control

## CONDENSERS

- C1—10 mfd. 25 volt electrolytic

- C2, C4—.01 mfd. 400 volt condenser
- C3—8 mfd. 450 volt electrolytic (optional)
- C5—25 mfd. 25 volt electrolytic
- C6, C7, C8—16 mfd. 450 volt electrolytic
- C9—.002 mfd. mica condenser

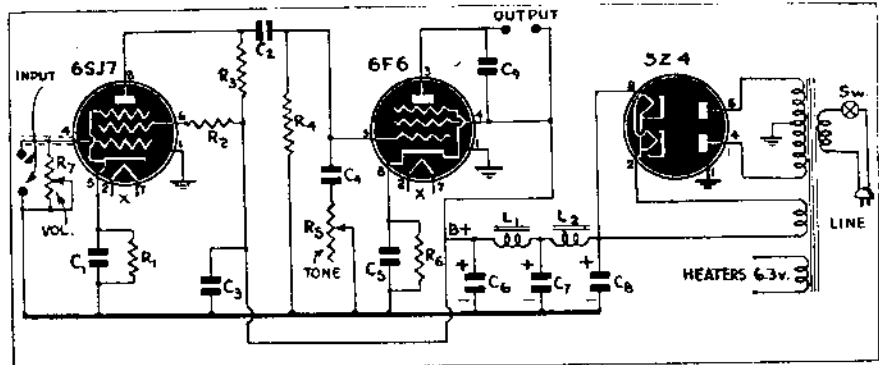
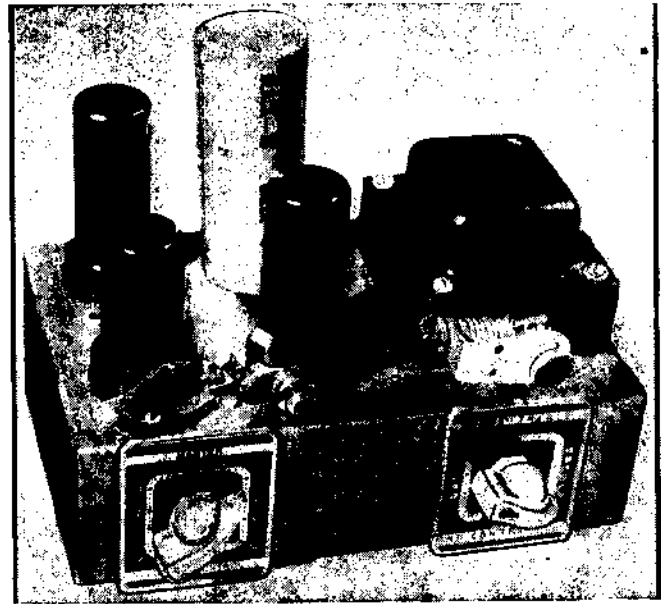

# AUSTRALIAN CHAMPION

**T**HIS simple amplifier is a national champion. It is the winner of a contest staged by the Melbourne (Australia) radio paper, "Listener-In," in conjunction with their Australian DX Radio Club.

Forty-two amplifiers were entered, and ten of these made the finals. These ten were allowed to play three recordings each, after which the judges announced their decisions. Proponents of the triode will be

interested to know that the contest narrowed down to a struggle between this amplifier and another push-pull 2A3 job.

That simplicity and high-fidelity go together is amply demonstrated by this set. Triodes are used throughout, as is resistance coupling. The phase inverter is the famous Australian "kangaroo" circuit. The plate resistor, and its balancer between the 6CS-G cathode circuit and ground, are kept to a low value, in the interests of high-fidelity. These resistors are often 100,000 ohms or higher, but in this amplifier are limited to 50,000.

The 6N7-G is then used as a straight push-pull amplifier. The plate resistors on these tubes are also kept down—to 100,000 ohms in this case—and grid leaks of the 2A3 are 250,000 ohms, the signal being transferred through .1-mfd. condensers. A fairly high voltage is used on the 2A3's. This also increases the efficiency of the resistance-coupled stages slightly.

Excellent filtering is a feature of this circuit. Even the push-pull output of the 6N7 circuit is filtered, in spite of the fact that most variations in this circuit would be self-neutralized. A 20,000-ohm resistor and an 8-mfd. condenser act as filter in the plate circuit of the first stage. No cathode

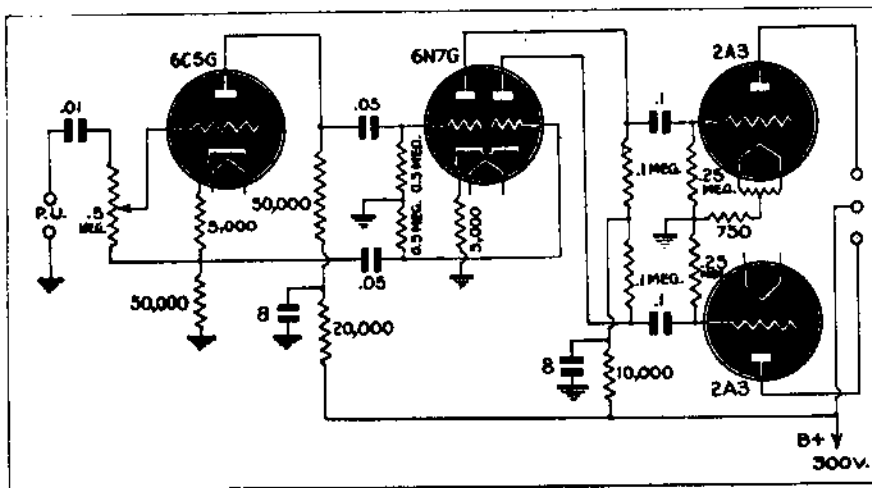

The single triode is used as a phase inverter, and the 6N7G as a straight push-pull amplifier stage. Triode tubes, excellent filtering and low resistor ratings all contribute to its fidelity.

(Continued on following page)



condensers are used anywhere in the amplifier.

The runner-up job also used 2A3 output, preceded by a 6V6 phase-changer. Fixed bias featured the circuit, which was nosed out by the winner only after a stiff battle.

The constructor of the champion gives credit for his victory to the infinite baffle used with his amplifier. Correct speaker loading and proper reproduction of low notes made for a noticeable increase in quality as compared with the same outfit used with an ordinary baffle, according to him. Full constructional details of this baffle are given in the sketch.

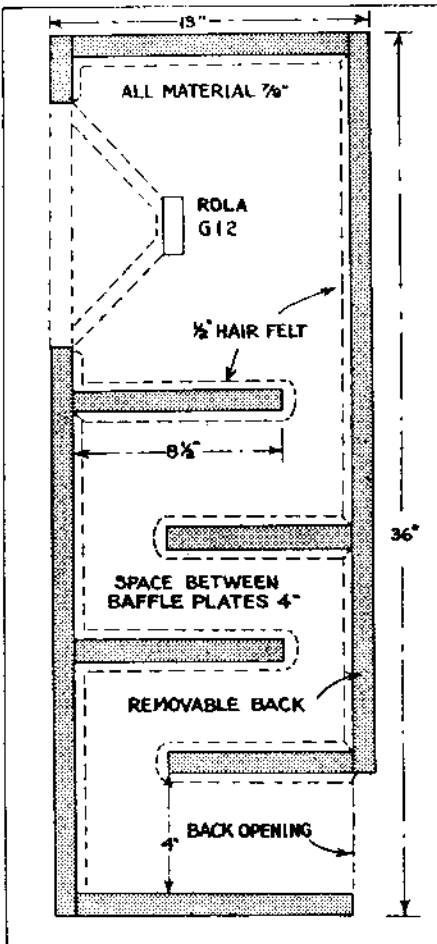

The speaker cabinet is the infinite-baffle type. Its width may be from 20 to 24 inches.

### NOVEL FEATURE IN P. A.

(Continued from page 20)

broadcast receiver.

It has its own power supply, using a 76 with plate and grid tied together as rectifier. Thus there is no possibility of coupling with the amplifier, as might be the case with a common power supply. I have actuated radios with it at a distance of 200 feet, though in practice this is never necessary.

#### Parts List

- R1—5 megs.
- R2, R6—1,000 ohms
- R3—1.5 megs.
- R4—0.25 meg.
- R5, R7, R8—50,000 ohms
- R9, R10, R12—100,000 ohms
- R11, R13—0.33 meg.
- R14—100 ohms
- R15, R16, R17—0.5 megohm volume controls
- C1—10 mfd. 25-volt
- C2, C9, C10—0.1 mfd. 400-volt
- C3, C11—0.1 mfd.
- C4, C6, C7, C8—8 mfd. 450-volt
- C5—4 mfd.
- C12—250 mfd.
- C13, C14—.02 mfd. paper

"I'M SURE OF FASTEST SERVICE FROM ALLIED"



# LARGEST AND MOST COMPLETE STOCKS

## Everything in RADIO and ELECTRONICS

More than 10,000 items are carried in stock for rush delivery . . . Guaranteed quality products of America's leading manufacturers! Save time and money — get all your needs from this one central source—and get that extra measure of satisfaction which only Allied — America's foremost Radio Supply House — can give you!



## FREE CATALOG OF OVER 10,000 RADIO ITEMS

KITS  
CODE APPARATUS  
TUBES, METERS  
TEST INSTRUMENTS  
TOOLS, BOOKS  
P. A. EQUIPMENT  
RECEIVERS  
TRANSMITTERS  
WIRE & CABLE  
and Thousands of  
Radio Parts  
Available  
Without Priority

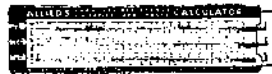

Parallel Resistance and Series Capacitance CALCULATOR.

No. X37-960 . . . . . 25c

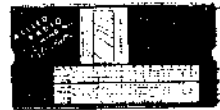

R. F. Resonance and Coil Winding CALCULATOR.

No. 37-955 . . . . . 25c



RADIO BUILDERS' HANDBOOK. Simplified theory and projects. No. 37-750 . . . 10c

DICTIONARY OF RADIO TERMS. Easy-to-understand definitions. No. 37-737 . . 10c

RADIO-FORMULAS & DATA BOOK. Handy, pocket-size manual. No. 37-752 . . . 10c

RADIO CIRCUIT HANDBOOK. Schematics and Pictorials. No. 37-753 . . . 10c

SIMPLIFIED RADIO SERVICING. Short cuts in troubleshooting. No. 37-755 . . 10c

RADIO DATA HANDBOOK. Formulas, Tables, Charts. No. 37-754 . . . . . 25c

### 6 VALUABLE RADIO BOOKS FOR 75c

Specially prepared by technical experts for radio training and for helpful reference. Priced only to cover cost of preparation and mailing.



Write for Quantity Quotations

#### ALLIED RADIO CORP.

833 W. Jackson Blvd., Chicago 7, Illinois

Please send following books ( . . . . . \$ enclosed)

- 37-750
- 37-751
- Free Catalog
- X37-960 Calculator
- 37-752
- 37-753
- Send All Six Books
- 37-755
- 37-754
- 37-755
- 37-955 Calculator

Name \_\_\_\_\_

Address \_\_\_\_\_

City \_\_\_\_\_ State \_\_\_\_\_

2-46



# AMPLIFIER MANUAL

By A. C. SHANEY

Chief Engineer, Amplifier Co. of America

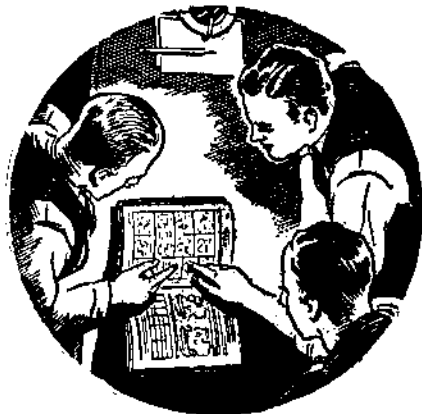

For the Layman, Serviceman  
Recordist and Engineer

Regardless of whether you are interested in the finest type of phonograph reproduction, high fidelity recording, sound-on-film applications, FM or AM programs, you will find invaluable information in this practical handbook. Written by the leading exponent of direct-coupled amplifiers who has spent more than 10 years improving and perfecting the famous Loftin-White circuit.

Explains the theory and practical application of:

Variable Speed Non-Overloading Push-Pull Expansion; Non Frequency Discriminating Scratch Suppression; Push-Pull Balanced Direct-Coupled Amplification; Push-Pull High-Frequency Equalization; Push-Pull Low-Frequency Equalization; Push-Pull Volume Compression; Automatic Volume Limitation; Automatic Volume Control; Calibrated V. U. Indicator; Audio Spectrum Control; Remote Control

If you are interested in the latest audio developments, you can't afford to be without this complete compilation of authentic articles on Direct-Coupled Amplifiers. 32 pages 8½" x 11". Over 100 diagrams and illustrations.

Priced to Cover Cost of **25c**  
Printing and Mailing

Please Send U.S. Stamps or Coin Only

**AMPLIFIER CO. of AMERICA**  
396 BROADWAY NEW YORK, N. Y.

## MATCHING LOUDSPEAKERS

(Continued from page 15)

reflected the correct impedance back into the primary.

The method of distributing power is simple enough. Many servicemen do it unconsciously. With two 8-ohm speakers to attach to an output transformer, few would have to be told they could both be connected in parallel across a 4-volt tap. Each speaker is faced with an impedance half its own, and receives half the power. What could be more simple, if we wish to divide the power in parts of one-third and two-thirds, to tap one speaker across a tap 1/3, and the other across 2/3 its impedance? All we have to do is multiply the voice-coil impedance by the fraction of the output we want it to take.

But will matching to the output tubes be correct? Back to the 8-ohm speaker and 4-ohm tap again! A 4-ohm speaker would reflect the correct impedance back into the primary, and maximum power would be drawn from the amplifier. The 8-ohm speaker reflects 8/4 or twice the correct impedance back into the primary. If two of them are paralleled, each reflects its 12,000 ohms. The resultant of these two 12,000-ohm impedances in parallel is 6,000, the correct load. If our two 8-ohm speakers are connected to divide the load into 2/3 and 1/3, the reflected impedances will be  $8 \times 3/2 \times 6,000 = 9,000$  and  $8 \times 3/1 \times 6,000 = 18,000$ . Adding these impedances in parallel, the resultant impedance is 6,000, which is what we want.

The method can be extended to several speakers, as in the example of Fig. 4. Here we wish to supply 2 watts to a 500-ohm line, 6 watts to a 16-ohm and 12 watts to

an 8-ohm speaker. This works out to 0.1, 0.3 and 0.6 of the total output (20 watts). Again assuming a primary of 6,000 ohms, we can get correct matching and power distribution by calculating output taps as follows:

For the 2-watt 500-ohm line,  $500 \times 0.1 = 50$  ohms; for the 6-watt, 16-ohm speaker,  $16 \times 0.3 = 4.8$  ohms; and for the 12-watt, 8-ohm tap,  $8 \times 0.6 = 4.8$  ohms also. Reflected impedances are  $6,000 \times 10 = 60,000$ ;  $6,000 \times 10/3 = 20,000$  and  $6,000 \times 10/6 = 10,000$ . These paralleled impedances add up to 6,000 ohms.

By the above method it is possible to hook up the most complicated speaker combination. All that is necessary is to know the impedance of each speaker and the portion of the total amplifier power we want to put into each one. Another essential is an output transformer with a variety of taps. In conclusion, it might be well to point out that an output transformer has a large number of impedances not marked. For example, the impedance between the 2-ohm and 16-ohm tap is 6.6 ohms. Sometimes these odd ohmages make a closer match possible than would otherwise be the case.

### References:

Matching Loud-speakers to Tapped Transformers, A. Coblenz, *Radio-Craft*, July, 1938, Page 26.  
A. F. Amplifier Load-Matching Technique, A. C. Shaney, *Radio-Craft*, March, 1940, Page 538.  
Speaker Matching Technique, H. S. Manney, *Radio-Craft*, June, 1940, Page 732.  
Output Transformers, Fred Shunaman, *Radio-Craft*, September, 1943, Page 726.  
Matching Speakers of Unequal Impedance, Richard W. Crane, *Electronics*, February, 1944, Page 256.

## RECORD CHANGERS

(Continued from page 27)

of ancient vintage. Many still in use date back to "tin-horn" days. Unfortunately, the man who made them had none of the qualifications of Nostradamus. Not being able to predict the future, he failed to design them to work on an automatic record changer.

This is not difficult to explain if a new record is available for comparison. The eccentric groove around the center can be pointed out as the means for actuating the repeat cam. This will not be found on the old record. Also, old records can be seen to vary from the standard thickness of modern records.

(Never suggest the obvious cure of discarding the old records. Remember, they are valuable "heirlooms," to be broken only by grandchildren.)

### Symptoms

Failure to repeat and jamming of the record selector mechanism.

### 5. Bent Records

The worst treatment that can be accorded phonograph records is to forget to remove them from the selector blade supports and leave them there for several days. In this position, the stack of discs is not resting on a flat surface like the turntable, but is supported either from two points at the sides, or at one side and the center. In the first case the discs will sag in the center and in the second they will sag at the unsupported edge. When this

sag becomes fixed the recordings may be so badly warped that they cannot rest flat on one another and the selector blades will not be able to slide between them to separate one record at a time from the stack.

### Symptoms

The "wow" effect of warped records on the music is well known and many complaints that the motor is "dragging" or alternately speeding up and slowing down can be traced to this reason, especially if the unit refuses to misbehave when the repair man is present. Look through the record stack for the offenders.

### Procedure

Before actual repair work can be accomplished a device must be provided by which the player can be supported in a right-side-up and level position, since this is the only position in which it can be tested for proper operation. The writer finds that two small boxes taken from the stock shelf are quite practical for this purpose (see Fig. 1). Many service men prefer more elaborate supports installed in a permanent phono repair position. Naturally, some operations will require placing the player carefully upside down position (preferably on a felt pad or rubber mat).

The most expedient method usually begins with an inspection of the mechanism for broken and defective parts. These are either replaced or repaired, the accent

being on the latter procedure at present. In this connection an important caution should be observed in regard to replacing broken springs. (See Fig. 2.) If it is necessary to stretch a broken coil spring so that it can be put back in its original location, some arrangement must be used to avoid excessive tension. Remember that springs are used merely to bring the levers back to their original positions and minimum tension should be used to avert wear at points of friction.

After mechanical repairs have been effected, resetting of adjustments can be undertaken and will invariably be necessary due to the considerable effect one adjustment has upon another in this type of mechanism.

The underside of a widely used record changer is shown in Fig. 3 with its various components numbered to correspond with their adjustments as listed in the accompanying table. (Fig. 4).

### REMOTE JUKE BOXES

(Continued from page 7)

amplifier is transformer coupled in and out. Equalization is inserted in this amplifier to make it peak in the voice range, and frequency response being from about 80 to 6000 cycles.

In the middle of the Board can be seen a volume level meter. This meter is used across the output of each program amplifier to indicate the correct operating level. Below the decibel meter is a row of push-buttons. Each pushbutton is associated with a program amplifier output.

At no time during the playing of a record does the volume rise to more than minus 2-Db. on the peaks. The program amplifier output is set by using a record which has an abundance of high and low frequency passages. I suppose it will be asked, "Why not set the maximum program level by means of a standard audio frequency record." This has been found by actual practice to be useless for a good many reasons, the main one being that all crystal pick-up cartridges do not have the same voltage output for a given frequency, and also as they become weak through use this is a good check on their frequency response.

Hanging down from the front of the Board is seen the operator's breast-set. This consists of a pair of low impedance headphones, connected in parallel, and a dynamic microphone. Crystal microphones are little used in this type of work as they are not rugged enough for the abuse they get. Also the circuits are of low impedance to cut down noise and hum, and use of a high-impedance microphone would necessitate the use of an input transformer with its hum problems. The microphone can be raised or lowered to compensate somewhat for the different speaking voices of the operators.

Looking at the back of the Board as shown in the photograph, Fig. 2, is the following apparatus. At "A" in the upper left hand corner is the back of the permanent magnet speaker. In the upper right hand corner and labelled "B" are the two dial stepping relays.

In the middle is seen the back of the turntable motor. On the first shelf and to the left labelled "E" is the program monitor amplifier chassis. The phonograph pick-up amplifier consists of a dual 100,000-ohm potentiometer working into the grids of a 6N7 tube. The crystal pickup is not grounded on one side as is the usual practice. The 6N7 tube is transformer-coupled out to a 50-ohm line. The monitor amplifier con-

(Continued on following page)



**It's FREE! It's NEW!**

# CONCORD

## BUYING-GUIDE

and REVISED LISTINGS

# Radio Parts

**HUNDREDS OF PARTS LIKE THESE**  
—Many Available Without Priority



 <p><b>AUTO-LITE RELAY</b> Solenoid relay similar to relays on autos with push-button starters. 8.5 to 14 volts D.C., with heavy double make contacts. 3 3/8" x 3 3/8" x 2 1/4". A14516. Specially priced, <b>\$1.19</b></p>	 <p><b>MIDGET POWER TRANSFORMER</b> Pri. 117 volts, 60 cycles. Secondary 6.3 volts @ .5 amps, 150 volts @ 150 M. A., 50 volts @ 65 M. A. Size 3 1/4" x 3" x 2 1/2". A5959. Your cost, <b>98c</b></p>
 <p><b>6" PM SPEAKER</b> Ideal for AC-DC radios, P. A., and Intercom replacements. S B 7 0 0 0. Your cost, <b>\$1.98</b></p>	 <p><b>TAPPED RESISTOR</b> Vitreal resistor, 90 watts, 6.4 ohms resistance tapped in 20 steps of .32 ohms ea. 58197. Your cost, each, <b>89c</b></p>

## CONCORD RADIO CORP.

Lafayette Radio Corporation

CHICAGO 7, ILL. 901 W. Jackson Blvd.  
ATLANTA 3, GA. 265 Peachtree Street

**Mail Coupon Today for FREE BOOK!**

 <p><b>KURMAN RELAY</b> Type 223C34, S.P.D.T. contacts. 2.5v. D.C. 8 MA, 300 ohm coil. 58402J. Specially priced . . . <b>\$2.50</b></p>	 <p><b>AUDIO REACTOR</b> Sealed. .15 Mh at 0. D.C. current. Con 2" x 2 1/4" with 4 1/2" mfg. inserts. S B 5 0 1 0. Your cost, <b>\$2.95</b></p>	<p>Concord Radio Corp. 901 W. Jackson Blvd. Dept. RER-2 Chicago 7, Illinois</p> <p>Please RUSH FREE copy of CONCORD'S new 68-page Buying-Guide and Revised Listings. Just off the press.</p> <p><b>CONCORD RADIO</b></p> <p>Name . . . . . Address . . . . . City . . . . . State . . . . .</p>
--	--	---

## REMOTE JUKE BOXES

(Continued from previous page)

sists of an input transformer with a potentiometer across its secondary, into a 6J5 tube. This potentiometer not only controls the voltage on the grid of the next tube, which is a 6F6 tied triode, but also controls the volume level of the monitor speaker and the operator's headset. A second potentiometer in the grid of the 6F6 tube controls the volume level of the monitor speaker. On the above chassis is the copper oxide rectifier and relay that controls the stepping relay on the panel and the buzzer. On the same shelf as the above chassis and labelled "D" is the conversion unit, or line-adjusting chassis.

This unit consists of a resistance-capacity network and two 1:1 hybrid coils. A brief description of this unit which is very important to the frequency response and operation of the equipment is as follows:

The amplifiers will operate over a maximum length of ten miles of telephone line. However, these conversion units plus the amplifiers are designed to work over a seven mile class "C" telephone line or any unbalanced circuit of that length. Whether the line between the Central Station and the Remote Station be a full seven miles or any fraction thereof, the network in the conversion unit will make up the line difference so that to our equipment it still is a seven mile line.

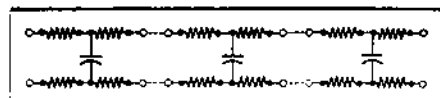

Fig. 5—Three sections of the artificial line.

The capacitance of this seven mile line was figured at 0.6 Mfd., and its resistance at 1,344 ohms. Thus each conversion unit (one being used at each end of the line) is divided to have a capacity of 0.3 Mfd. and a resistance of 672 ohms. Each of these units are divided into seven sub-units. There are three 1-mile line units, two 1/2-mile line units, one 1/3-mile line unit and one 1/4-mile line unit. Each of these units is arranged like an "H" pad, as shown in Fig. 5.

Each one-mile line unit consists of four 56-ohm resistors, and a 0.1 Mfd. condenser. Each 1/2-mile line unit consists of four 27-ohm resistors, and a 0.05 Mfd. condenser. The 1/3-mile line unit consists of four 15-ohm resistors and a 0.02 Mfd. condenser. The 1/4-mile line unit is made up of four 12-ohm resistors and a 0.02 Mfd. condenser. While 27-ohm and 15-ohm resistors do not figure exactly right, as stock resistors were used, they fall within the ten percent tolerance range and are all right for the purpose. There are two controls on the conversion unit, one for the high and one for the low frequencies. These controls peak the line at 100 cycles and 3000 cycles respectively. To equalize the line requires the use of an audio frequency oscillator and a calibrated volume level indicator with the necessary terminating equipment.

The second shelf is a duplicate of the first. On the bottom and labeled "F" may be seen the power supply which feeds the two program amplifier chassis above, including the lights for signalling, stepping relays, etc. The rectifier is a 5U4-G used in a full wave circuit.

### THE REMOTE INSTALLATION

The Remote Station: In Figs. 3 and 4

can be seen a front and back view of the "Juke Box" used at the remote location. Behind the metal grill at top center is the microphone which the customer uses to tell the operator the number of the phonograph record he or she wants to hear. Either a crystal mike or a small two-inch permanent magnet speaker with an input transformer is used as a microphone. Below this and just above the words "Rhythm-Air" are coin slots for the nickels, dimes and quarters. Behind the three metal bars in front of the Box is the 12-inch, permanent magnet speaker.

A back view of the Box and its interior is shown in Fig. 4. To the left and on the bottom is the power supply with its 5U4G rectifier tube. This is labelled 1. Rear view of the speaker is 3 in the photograph. At top rear middle is the coin scavenger mechanism. This rejects any coin that is not of a non-ferrous nature and also any slugs that might be inserted. Below this and shown with a twin-pair conductor is the coin counting mechanism. This causes one pulse for a nickel, two pulses for a dime and five pulses for a quarter to be sent over the telephone line to the Central Station and operate the stepping relay. The voltage used is anywhere from 30 volts A.C., 60 cycle, to 110 volts A.C., 60 cycle. It depends on the length of the line and other factors, determined by trial.

On the right-hand side and fastened to the wall, labelled D, is the conversion unit. Just below this unit and marked 2, is the chassis containing the remote amplifier. The talk-back amplifier is on this chassis and depending on the type of microphone used, has either a resistance coupled input or transformer coupling to two 6N7 tubes in resistance-capacity coupling, push-pull. The output is transformer coupled to a 500-ohm line. A volume control is used in the grid of the first 6N7 which is a phase inverter for the second 6N7.

The power amplifier for the speaker is a transformer coupled 6N7, with a dual potentiometer volume control across its secondary, resistance-capacity coupled to two 6V6's. These two output tubes are transformer coupled to the speaker. A resistance-capacity filter across the plates of the beam-power tubes flattens out the amplifier response and provides an effective load impedance for all frequencies in the middle and upper range. This is used in place of degenerative feedback. Also on this chassis is a double-pole, single-throw, relay used for signalling the Central Station.

Sometimes the speaker is taken from the "Juke Box" and put in an ornamental baffle. This makes for better intelligibility of speech and quality of music.

A brief description of just what takes place when a coin is inserted in the Remote Location "Juke Box" is as follows: A coin

is dropped through the counting mechanism and—depending on its value—causes a contact to close, this operates the double-pole, single throw relay on the Remote Amplifier chassis. When this relay closes it sends the voltage which has been chosen (30 to 110 volts A.C. 60 cycle) from an isolation transformer on the power supply, over the telephone line to the Central Station. When reaching the Central Station this voltage impulse is rectified by a full-wave copper-oxide rectifier and as a D.C. voltage operates the single-pole, single-

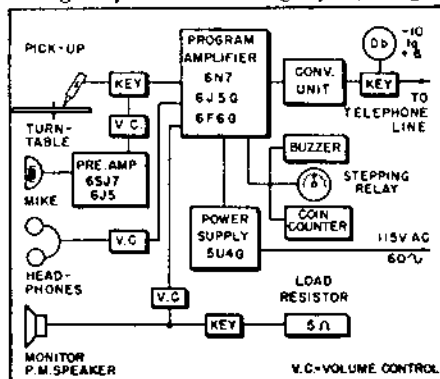

Fig. 6—Rough diagram of the Central Station.

throw relay on the program amplifier chassis. When this relay closes it operates either the stepping relay on the front panel or the buzzer.

When the operator sees the stepping relay operate or hears the buzzer, she throws the triple-pole, double-throw key between and at the right hand side of the turn-tables. This connects her headset through the monitor amplifier to the incoming telephone line, and also connects the output of the microphone pre-amplifier to the same line. She then can not only hear what record the customer would like to hear played but also talk back to him. If the record is not avail-

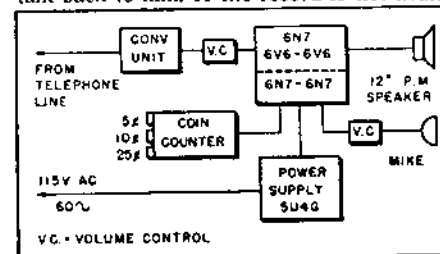

Fig. 7—Block diagram of the remote receiver.

able, she can ask him to request another. When the operator throws the key to talk to the Remote Station, it automatically drops the level of the phonograph record that might be playing at that time so the customer can hear her voice over the music.

A block diagram of the Central Station equipment and also the Remote Station equipment is shown, in Figs. 6 and 7. When the telephone lines are equalized and balanced, their frequency response is within 1/2 Db., from 100 to 6000 cycles.

## SIGNAL TRACER—PLUS

(Continued from page 8)

As one of the photos shows, another 6K7 was tried, to boost the R.F. gain. The oscillation problems were difficult to surmount and most of the extra gain was lost in reducing voltages and adding bias in order to stop the oscillation. The output was very little better than with one R.F. stage. As it now stands the one untuned 6K7 and untuned 6J7 provide enough gain

to trace the signal from the grid of the first tube right on to the detector, from which point the probe is shifted to the audio input jack and the signal traced right on to the loud-speaker.

The use of such a tester is a revelation to one who has never used a signal tracer. Oscillation can be traced right down to the offending tube by bringing the probe

somewhere in the neighborhood of the tube plate prong. Hum and noise can be picked up just as easily. Loss of gain can be isolated right to the offending stage.

A real set of test prods made as the photos show will prevent any detuning of the circuit under test. If the parts are available the shielding test probe shown will prove a valuable addition to the tester. Use 30 inches of microphone cord and bring the end of the shield out in a phone tip which is to be inserted in the ground jack. When testing the grid circuit of the first tube the ground tip should be removed from the ground jack to increase the signal strength, as the shield acts as a small condenser by-passing some of the R.F. energy to ground.

The small capacity tip is made by turning or grinding down a small phone-tip jack in a lathe or grinder until it is just a thin shell. Cut the end off to fit the length of the insulator of the phone tip (See Photo). Insulate the turned surface of the jack with wax paper and wind on 50 turns of wire from an old transformer secondary. Fasten the wiring by painting the coil with dope. Test the assembly for continuity to be sure you have no short. There must be no direct connection; only a small capacity coupling between the coil wire and the jack should exist.

When cutting off the end of the jack to fit the space within the insulated phone tip, the gripping jaws will slip out. To hold the assembly together solder the jaws and the end of the jack together.

The A.F. tip probe was made by cutting off a phone jack and soldering a 50,000 ohm resistor to the end of the jack and the inside gripped jaws. The photo is self explanatory. When using the tester only one such probe is necessary if the tester ground and the set chassis are connected together with a jumper. The same probe can then be used for all voltage and resistance tests by using it without the tips, which are easily put on and removed.

## THE VOLT-OHMMETER SECTION

As we had a power supply the tester could be adapted to many more uses. It is a handy Volt-Ohmmeter, also a condenser and continuity tester. My only transformer had a 2½-volt filament winding so I selected tubes which could be wired in series with a line cord resistor. Other tubes can be used in their places if they have the same current drain. Any tubes of similar type can be substituted if you can supply 6.3 volts on the filament winding. If so you can do away with the line-cord resistor.

The voltmeter has 4 ranges: ½, 25, 150 and 500 volts, which are selected by the 4 positions of the gang wafer switch (to the right in diagram). The lowest range was selected for ohmmeter work only. The resistor values given are for my 2,000 ohm-per-volt meter, which has a resistance of 47 ohms. For a 1 Ma. meter these values should be halved.

The ohmmeter uses the same pin jacks that are used for the voltage tests. The gang wafer switch which selects the voltage range also operates a voltage divider on the second wafer when the switch No. 3 on the front panel is thrown. This switch may be combined with potentiometer R. The voltage divider was constructed to give a full scale reading on the meter of the 500-volt scale. The adjustment of the pot. R is for the full-scale adjustment. The circuit is arranged so that the same voltmeter jacks are used and the test prods are in parallel with the meter. Shorting the prods shunts all the current away from



1. Brand new post-war design . . . positively not a "warmed-over" pre-war model.
2. More than an "electronic" voltmeter, **VOMAX** is a true vacuum tube voltmeter in every voltage resistance: db function.
3. Complete signal tracing from 20 cycles through over 100 megacycles by withdrawable r.f. diode probe.
4. 3 through 1200 volts d.c. full scale in 6 ranges at 50, and in 6 added ranges to 3000 volts at 125 megohms input resistance.
5. 3 through 1200 volts a.c. full scale in 6 ranges at honest effective circuit loading of 6.6 megohms and 8 mfd.
6. 0.2 through 2000 megohms in six easily read ranges.
7. -10 through +50 db. (0 db = 1 mw in 600 ohms) in 3 ranges.
8. 1.2 ma through 12 amperes full scale in 6 d.c. ranges.
9. **Absolutely stable**—one zero adjustment sets all ranges. No probe shorting to set a meaningless zero which shifts as soon as probes are separated. Grid current errors completely eliminated.
10. Honest, factual accuracy. ±3% on d.c., ±5% on a.c.; 20% through 100 megacycles; ±2% of full scale, ±1% of indicated resistance value.
11. Only five color-differentiated scales on 4½" D'Arsonval meter for 51 ranges (including d.c. volts polarity reversal) eliminate confusion.
12. Meter 100% protected against overload burnout on volts/ohms/db.
13. Substantial leather carrying handle. Size only 12¾" x 7¾" x 5¾".

SEND FOR FREE CATALOG

OVER 34 YEARS OF RADIO ENGINEERING ACHIEVEMENT

*McMurdo Silver Company*

1240 MAIN STREET, HARTFORD 2, CONNECTICUT

## "VOMAX" THE KEY TO POST-WAR PROFITS

Created by a world-famous receiver design engineer specifically for post-war receiver servicing . . . that's why "VOMAX" will do more for you . . . make you the boss, not the victim, in servicing complex post-war receivers.

It's one thing to design test equipment by theory . . . but it's quite another thing when new and original theory is harnessed to over thirty-four years of outstanding experience in radio receiver design and service. Created out of such experience to satisfy the rigorous demands of serious research and service technicians, the new "VOMAX" is a volt-ohm-db.-ma.-meter and dynamic signal tracer without equal. Born out of an intimate daily knowledge of your job and problems . . . it solves them as you've always hoped they would someday be solved.

Imagine the added profits earned . . . the time saved . . . the immense improvement in your work . . . if you had an instrument with which you could measure every voltage in old, modern and complex post-war receivers. Imagine the benefits of being able to trace and measure r.f., i.f., a.f., a.v.c., a.f.c. signals right through every circuit . . . d.c. and any frequency from 20 cycles through over 100 megacycles. Imagine all measurements . . . d.c., a.c., r.f., i.f., a.f., made with such astronomically high meter resistance as not to upset the circuit being measured. Add resistance measurements by modern v.t. method . . . even power input in watts, a wide range of capacitances by a couple of external resistors. Then imagine complete stability and dependability . . . results made possible by new inventions obtainable only in "VOMAX."

It's no wonder "VOMAX" is sold out for 1945 on advance jobber orders. But though the factory is sold out, jobbers still have a few left. May we suggest that you follow the lead of America's top-flight service organizations . . . manufacturers . . . engineering laboratories . . . and place your order immediately? Service-station-originatee A.A.S. priority does the job. But only fast action will bring you "VOMAX", the key to post-war service profits, this year.

NET PRICE

\$59.85

the meter, which reads zero on a dead short. The scale can be calibrated with a known set of resistances. If a sensitive meter is used values of resistances from 1 ohm to 2 meg. can easily be read. The voltage available at the jacks can be used for experimental purposes while the meter reads the voltage actually supplied.

The ohmmeter provides a very accurate condenser tester, especially for the 25 and 150 volt electrolytic condensers. This is the only tester I have seen capable of testing the leakage and capacity of the low voltage electrolytics. The range switch is thrown to the proper range, let us say 25 volts and the voltage divider switch turned on. Adjust the meter for full scale deflection and insert the test leads in the ohmmeter jacks. The prods now have 25 volts DC across them which can be placed across the electrolytic, watching the polarity as

usual. The meter needle will dip on the charge and return to almost full scale if the condenser is good. Discharge by shorting the condenser leads. The meter needle will read zero on a shorted condenser and will not dip on an open-circuited condenser as the prods are applied.

For 150 and 450 volt filters and continuity tests the prod is changed to the neon tube jack which is No. 3 on the front panel, and the range of voltage is selected as before by the wafer switch. The two-watt neon bulb was purposely left inside of the tester where it is dark so that very small leakages and small capacities will be much easier to see.

As 25 volts will not light the neon tube such low voltage condensers must be tested as above. The meter test is just as good as the neon test if not better and can be used for the higher voltage condensers.





# MODEL 504-A Tube and Set TESTER....

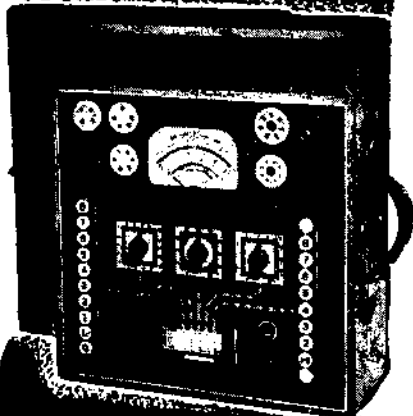

## ★ THE PORTABLE LAB THAT GIVES YOU— *Everything!*

- ★ Design proven by over 5 years production of thousands of this model.
- ★ Operation as simple as ABC. Multifunction push-button switches do all work. Simply "follow the arrows" for tube checking. No roaming test leads for the multi-meter.
- ★ Open face wide scale 4 1/4-inch rugged meter built especially for this tester—500 micro-ampere sensitivity.
- ★ Each AC and DC range individually calibrated.
- ★ Professional appearance. Solid golden oak carrying case.
- ★ Guaranteed Rectifier.

## SPECIFICATIONS

- DC MICROAMPERES:  
0-300
- DC MILLIAMPERES:  
0-2.5-10-50-250
- DC AMPERES  
0-1-10
- DC VOLTS—1000 OHMS PER VOLT:  
0-5-25-100-250-500-1000-2500
- AC VOLTS  
0-5-10-50-250-1000
- OUTPUT VOLTS:  
0-5-10-50-250-1000
- OHMMETER:  
0-200-2000-20,000 OHMS  
0-2-20 MEGOHMS
- BATTERY TEST:  
Check Dry Portable "A" and "B" Batteries Under Load
- CONDENSER CHECK:  
Electronics checked on English Reading Scale at Rated Voltages of 25-50-100-200-250-300-450 volts.
- TUBE TESTER:  
Emission type with noise test, floating filaments, easy chart operation. Checks all receiving type tubes.
- POWER SUPPLY:  
115 volts 60 cycle. Special voltage and frequency upon request.

# SUPREME

SUPREME INSTRUMENTS CORP.  
Greenwood, Miss., U.S.A.

## A CHASSIS CRADLE FROM PIPE FITTINGS

THE sturdy chassis cradle illustrated permits working over a radio set with all wiring, etc., in full view, but without the usual hazard to tubes and other components. The rig can be quickly constructed.

All parts, including the "C" clamps, can be obtained from your local hardware-plumbing supply house. The lengths of pipe listed all come pre-threaded. The parts list follows: "A" is a twelve-inch length of pipe. Four required. "B" is a Tee. Three

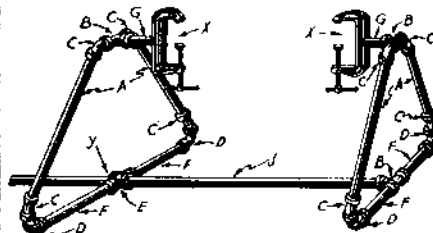

The chassis cradle above was built entirely of ready-cut easily-obtained pipe fittings.

required. "C" is a 45-degree Street Elbow. Eight required. "D" is an Elbow (90 deg.). Four required. "E" is a Cross. One required. For "F," 4 nine-inch lengths of pipe. "G" requires 2 six-inch lengths of pipe. "J" as desired, but should be about twelve inches longer than the longest chassis you are accustomed to repairing. For convenience it might be well to have two different lengths. This is the one part that does not require to be rigidly tight. Thus it can be changed at will and permits easy "knock-down" when it isn't required on the bench. For "X" use two "C" clamps. These should be the five-inch size, accommodating almost all chassis.

At point "Y" on the illustration it will be necessary to file down the thread with a large rat-tail file in one direction of the cross so that part "J" can ride through smoothly. By the same token there should be no thread on the free end of "J."

By making the sleeve "Y" smooth so that it slides easily over "J" but with no free play, a very rigid yet easily-adjusted cradle may be made. The chassis forms a top support when clamped in place, thus adding another brace. Thus it becomes unnecessary to secure "J" in any way, though the perfectionist may prefer to drill and tap "Y" for a set-screw.

One threaded end should be cut off "G" so that its over-all length will not be more than four inches. The unthreaded end should then have a slot cut in it to accommodate the web of the "C" clamp, as shown. The "C" clamp should then be welded into the slot. This operation is, perhaps, the only one you will not be able to accomplish alone. If you have no welding rig, you will probably be able to negotiate help from the local garage man who repairs broken automobile fenders. It will take him only a few minutes.

The most useful size for pipe and fittings should be from one to one and one-half inches. The "C" clamps should be installed in the positions shown in the illustration so that the clamping pressure will come up against the top of the inverted chassis.

I have found pipe fittings very useful in the radio shop. They come in a number of ready-cut lengths, which can be employed with elbows, bases for attachment to wood benches, and other fittings, to build up numerous handy devices.

# Proven!

25,000 OHMS PER VOLT  
PUSH BUTTON OPERATED  
SPEED TESTER  
SUPREME MODEL  
592



- ★ Design proven by over 5 years production
- ★ Dual D.C. Sensitivity—25,000 ohms per volt and 1000 ohms per volt.
- ★ Matched resistors of 1% accuracy
- ★ Push button operated—no roaming test leads
- ★ Open face—wide scale 4 1/4" meter. 40 microamperes sensitivity.
- ★ 1 Microampere first scale division.

## SPECIFICATIONS

- D.C. MICROAMPERES:  
0-70-700 microamperes
- D.C. MILLIAMMETER:  
0-7-35-140-350 milliamperes
- D.C. AMPERES  
0-1-4-14 amperes
- D.C. VOLTS, 25,000 OHMS PER VOLT:  
0-3.5-7-35-140-350-700-1400 volts
- D.C. VOLTS, 1000 OHMS PER VOLT:  
0-3.5-7-35-140-350-700-1400 volts
- A.C. VOLTS, 1000 OHMS PER VOLT:  
0-7-35-140-350-700-1400 volts
- OUTPUT VOLTMETER:  
0-7-35-140-350-700-1400 volts
- DECIBEL METER:  
0 db to plus 46 db
- OHMMETER:  
0-500-5000-50,000-500,000 OHMS  
0-5-50 MEGOHMS
- POWER SUPPLY  
Battery Operated

With the above specifications the Supreme Model 592 Speed Tester meets today's requirements for general laboratory use, assembly line tests and inspection, radio and other electronic repair and maintenance.

# SUPREME

TESTING INSTRUMENTS

SUPREME INSTRUMENTS CORP.  
Greenwood, Miss., U.S.A.



## FIXED-BIAS AMPLIFIERS

(Continued from page 18)

the one found in 90% of the commercial A.C. sets. In this type, a resistor is inserted between the power transformer's high voltage secondary center tap and ground. The entire B+ current must pass through the resistor in such a direction that a voltage, negative with respect to ground, builds up across the resistor. By using the correct resistance value, the correct voltage for biasing the output stage may be obtained.

This circuit is still far from true fixed bias. The drop across the negative-bias resistor prevents the full voltage output of the power supply from being effective as "B" voltage, and the current through it is not steady. We have only succeeded in moving the second disadvantage of ordinary cathode bias to another part of the circuit and in reducing but not eliminating the first disadvantage, that of varying bias voltage.

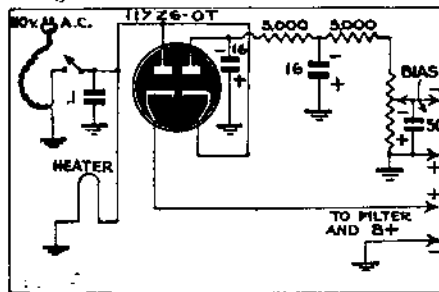

Fig. 3—One 117Z6-G used to supply high and bias voltages for receiver or amplifier.

This circuit works best in a large amplifier or radio where a number of tubes and perhaps a high-current bleeder draw current through the bias resistor. Since the

find the extra chassis space required to bias a single tube by this method.

### A TRUE FIXED-BIAS JOB

A bias voltage developed by a current which will be absolutely constant and independent of varying tube conditions may be reached in the circuit of Fig. 2. This unit makes a most satisfactory phono amplifier with an amazingly low distortion level and high output. The cathode of the 1-V bias rectifier is connected to one of the high voltage transformer leads. It is obvious that this connection of the rectifier will cause a negative voltage approximately equal to the R.M.S. transformer rating for one-half the high voltage secondary to appear across C1.

We are now faced with the problem of dropping the voltage to the required values for biasing the tubes and of filtering said voltage particularly thoroughly, since we are using half-wave rectification. These two purposes are accomplished at the same time by the two resistors R1 and R2, which act as dropping resistors and also as filter resistors in conjunction with C1, C2, and C3. Owing to the high values of R1 and R2, filtering is very efficient, thus reducing hum to a minimum. C4 further filters the bias to insure hum-free operation of the more sensitive first audio stage. R3 and R4 are I.R.C. potentiometers with metal backs by the aid of which they were soldered to the under-side of the chassis. Their shafts were cut off fairly short and slotted to provide screw-driver adjustment. The bias voltages should be measured at the center terminals of the potentiometers themselves with an accurate and sensitive voltmeter, and no attempt should be made to measure

## Do you need BINDING POSTS?



The XL PUSH POST with its Spring Action assures Constant Contact and quick connection. Manufactured in All Aluminum Type M at 12c each. Aluminum Body, Bakelite Top Type B1 at 15c each. Types CP or NP (Cadmium or Nickel Plated) ALL BRASS STAINLESS STEEL SPRING & PIN. PROVEN in Gov't. Laboratory by 240 HR. SALT SPRAY TEST as NON-CORROSIVE. at 28c each.

Manufacturers and Dealers Liberal Discounts

**X. L. RADIO LABORATORIES**

420 West Chicago Ave., Chicago 10, Ill.

unbalancing of the power transformer's high-voltage secondary by drawing appreciably more current off one half than off the other. The values given in Fig. 2 were found to be quite satisfactory with this circuit. The potentiometers should be such that the desired bias voltages can be obtained by setting the arm of each pot near the center of its range. The values given for R3 and R4 in the diagram should work perfectly well.

This method of biasing is particularly applicable to A.C.-D.C. systems, where one rectifier can be made to serve for both power and bias supplies. See Fig. 3.

Other tubes such as the 25Z6, 50Z7G and 50Y6GT may be similarly connected, the only difference being in the filament ratings. Thus the designer can choose a rectifier which will have filament requirements such that it may be used in conjunction with the other tubes he intends to use. This double use of the two portions of a double-diode rectifier is similar to a voltage doubler, the difference being that in this application the voltage is calculated plus and minus from the zero ground point, where in the doubler both voltages add up from that point.

### A GOOD AMPLIFIER

Finally, I give the circuit (Fig. 4) and general view (photograph) of another amplifier operating on the same principle as the units of Figs. 2 and 3 but of greater power output. The 6L6G in the output stage will deliver full 10 watts at a minimum of distortion. The power transformer delivers 375 volts R.M.S. each side of the center tap, at 150 ma. For this reason the author thought it necessary to use a separate, ungrounded winding for the 1-V heater to insure against breakdown between cathode and heater. This is probably not necessary, but it is best to be on the safe side. Moreover, a small resistance was inserted as shown between the 1-V plate and the first filter condenser, since the light load placed on the 1-V by the bias voltage divider will otherwise cause an excessive voltage to build up across said condenser: as it is, a 500-volt rating is desirable for that part. In other ways, the bias supply is similar to the one of Fig. 2. The rest of the amplifier follows standard practice.

It should give long and trouble-free service at an efficiency, output level, and distortion level seldom equalled in single tube class A1 output stages using the available receiving-type tubes.

In closing, let me urge again the importance of well-regulated bias for maximum efficiency, power output and minimum distortion.

I trust that one or more of the ideas of circuits suggested in this article will be of some help to those ambitious amateurs who want to get as much out of their tubes as the commercials do. Try it once and be convinced!

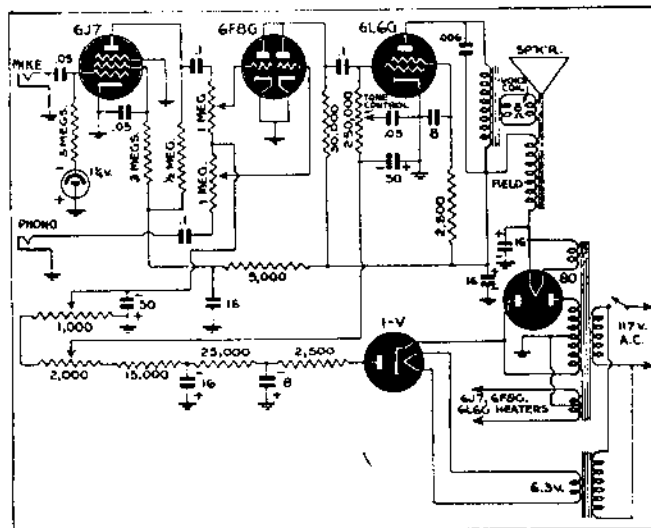

Fig. 4 — The amplifier illustrated at the head of this article. Real fixed bias, stability and freedom from coupling between stages result in ten watts of undistorted output from one 6L6.

plate current variations in one stage are 180 degrees out of phase with the variations in the next, the average bias current in such sets may be fairly close to constant. Another disadvantage is a greater tendency toward hum, which requires a series of decoupling resistor-condenser networks, to prevent the hum from reaching the grids of the audio tubes. Extra filtering is also required. Low supply voltage and additional difficulty in filtering the output of a half-wave rectifier make the system entirely impractical for A.C.-D.C. sets. It is cheaper to use two tubes in push-pull with cathode bias than to buy the condensers and

the bias at the grids of the tubes unless it is done with an electronic voltmeter. The potentiometers provide exceedingly fine adjustment of the optimum bias voltages (—8 volts for the 6C5 and —20 volts for the 6F6).

In hooking up the amplifier, one should be sure to ground the positive leads of C1, C2, C3, and C4, since the voltage being filtered is negative with respect to ground. The values of R1 and R2 may be allowed to vary over quite a range. In general, the current drawn by the bias system should be kept pretty low—around 10 ma. or less—to avoid unnecessary current drain and

## TRANSMISSION LINES

(Continued from page 23)

short sections shows that these two impedances approach each other with remarkable speed, and a point is soon reached where they are so close it is hardly worth while to add more sections. If the impedance of the line when open is (for instance) 201 ohms, and that of the same section shorted, 199 ohms, we must believe that however far the line is extended, the impedance will be close to 200 ohms.

If we are working with short lines at low frequencies, and cannot bring these impedances so near together with the length of lines at our disposal, the "characteristic impedance" can readily be calculated. Simply measure the open-circuit and short-circuit impedance of the section and take the geometrical mean. (Multiply the two figures together and get the square root of the product.)

The single-wire line is a special case. Its impedance cannot be easily computed, and is usually taken as about 500 ohms, though obviously it must vary somewhat according to its surroundings.

### A FINITE "INFINITE LINE"

Now for the reason we have made the line infinitely long. High-frequency (or other) currents are not bothered by standing waves on such a line. They just keep right on going—there is nothing to reflect them back. This is why even very high frequencies can be piped down such a line with the ease of D.C. in a battery circuit without bothering about tuning.

Again our watchful student breaks in. "But there ain't no such animal!" he insists. "First you introduce your infinite line simply as an illustration, and now you are proposing to run current along it. You are simply trying to kid us."

There is no intention of trying to deceive the reader. We are out for bigger game. What we intend to do is kid Mr. High-Frequency himself! And that can be done by a very simple trick. It has already been made clear that at any point on our hypothetical 200-ohm line, the current sees a 200-ohm impedance before it. We simply cut the line at any convenient point, and slip a 200-ohm resistor across the open ends. The effect is the same as if the line extended into infinity. The current has no way of finding out that it doesn't!

### TERMINATIONS THAT TAKE POWER

So now we can get an infinitely long line into a good-sized room. Our problems are not all solved, however. We must not only find a way of terminating the line so that it looks infinitely long to the currents travelling on it, but we have to get them off that line again, if we are going to deliver any power to another circuit.

This is comparatively simple. If we are working with 60-cycle current, all we have to do is terminate our line with a transformer winding, motor or other piece of apparatus so designed as to present the proper impedance to the line. You can then take power from the finite "infinite line" with no trouble.

The same thing can be done with radio frequency. In most cases transmission lines are used to carry currents from a transmitter tank to an antenna system. We have learned that the impedance of a straight half-wave antenna is close to zero at the center and practically infinite at the ends. We can therefore, by connecting across larger or smaller sections of it, match any desired impedance. This can be done as

shown in Fig. 3, (a) and (b). The ordinary "doublet antenna" of Fig. 3 (a) is fed by a transmission line of about 75 ohms impedance, so connected that the ends are about ten inches apart, at the center of the antenna. The impedance at this point is close to 75 ohms. To prevent shorting our transmission line, the center 10 inches of the antenna is taken out and an insulator inserted. This is another example of the tricks you can play on radio frequency. The antenna is used to meeting an impedance of 75 ohms at this point, and does not know that its middle section has been taken away and the line inserted instead. On the other hand, the line, meeting its characteristic impedance of 75 ohms, imagines that it extends indefinitely.

If we have a higher-impedance (wider-spaced) "feeder" we simply connect its ends to points farther from the center. In this case it is not necessary to use insulators, the feeder terminals "looking into" the same impedance, whether they look to the center or the ends of the line. (This type of connection is actually not quite as simple as that, because it is made across points on the aerial which present a higher impedance than the characteristic of the straight part of the line, and the line impedance increases steadily through the V-shaped portion, which acts as an impedance transformer.)

(The term "feeder" used above follows transmitter terminology, because these lines have become very popular in transmitters. The line is fully as applicable to receivers, and is as much a transmission line when it is transmitting energy from the antenna to the input coil of a receiver as when taking it from the output of a transmitter to the aerial.)

When a transmission line is used to couple two coils together, as in a transmitter, the job is even easier. Such "links" are made with a turn or two of wire at each end, as coupling loops, and coupling to the coils is varied for best results.

## CAPACITOR CHECKERS

(Continued from page 24)

When testing electrolytic condensers for leakage care must be taken to connect them for correct polarity, although accuracy does not warrant it, and the condenser will certainly not be harmed by the brief application of incorrect voltage while it is under test.

The leakage test may be used for detecting leakage anywhere, but its main purpose in this unit is for detecting leakage in condensers. The neon lamp employed should have a striking voltage of about 80 volts as the voltage available is only 100 volts. When a condenser is connected across the leakage terminals the neon lamp will flash momentarily, due to charging. If the condenser is good it may take a short time until the next flash. A leaky condenser will flash every second or so, and one that is really in bad shape will show a continuous light. Care must be exercised when applying the above principles to electrolytic condensers, as they always have a certain degree of leakage.

The rectifier circuit used in the bridge introduces some novel details. The tube employed is that versatile diode, the 6H6,

which has gained so much popularity for use in detection, AVC systems, electron voltmeters, etc., and is employed in this bridge in the capacity of a low voltage half-wave rectifier. One of the main reasons for its inclusion was the limited space available for construction and that a metal rectifier was unobtainable. Secondly, the heater has the same rating as the 6E5. Thus the filament transformer winding serves both. Last but not least, the current per anode of the 6H6 is 4 milliamperes. All that is required is the current drawn by the 6E5 target and triode plate current -- approximately 1.5 milliamperes at 100 volts-- so the 6H6 is not overloaded by this small consumption. On actual tests the total consumption of the unit was 1.6 milliamperes, a light load for even the 6H6.

### CALIBRATION FOR CAPACITY

The voltage supplied to the 6E5 target is approximately 115 volts, which is sufficient for efficient operation.

A double-pole double-throw toggle switch is incorporated in the instrument, so that scales calibrated on resistance will also hold good for capacity. By employing this switch, the action of the bridge is reversed for capacity measurements, thus enabling a single scale reading from .01 to 100 to be employed for both. All that is necessary in the operation is to place the switch in the correct position when measuring a resistor or a capacitor. The values of the standards chosen are in multiples of 10. Thus the reading on the scale is multiplied by the value of the range on which the measurement has been made. For instance, if a resistor is being measured on the 100-ohm range and a reading of .4 is obtained, then the value of the resistor is .4 times 100, which is of course, 40 ohms.

The resistance R1—of value 1000 ohms 3 watts—in series with the transformer and potentiometer automatically graduates the bridge voltage to suit the impedance being measured. It will be seen that for resistances of high value and condensers of small value, the full 50 volts is available and for low impedances which at a voltage of 50 would pass too much current both for themselves and the transformer, the voltage falls to a suitable value. Even if the test prods are accidentally shorted, no harm will ensue. It will be noted that 3 megohms is the value employed for the grid-cathode resistor of the 6E5 tube, but this value is not a hard-and-fast one, as during test operations of the instrument it worked successfully with values between 2 and 5 megohms. If there is any sign of the 6E5 overloading an increase in this resistor is advised. Overloading is indicated when in place of a shadow a patch of extreme brightness appears. The resistor in the power supply, R2, of 10,000 ohms, 2 watts, may be increased or decreased to obtain the correct potentials at the 6E5 target and anode, which in this case is 100 volts. The bridge may also be used to supply a variable 60-cycle signal up to 50 volts.

One final point in connection with the various bridges described. The accuracy of the bridge will depend on the accuracy of the standards employed, and resistors and capacitors of close tolerance should be obtained. The accuracy of the last described bridge is between 1% and 5% depending on tolerance of standards. For all practical arrangements this will be accurate enough for servicemen, amateurs and experimenters. If higher standards of accuracy are required, the next item is an elaborate laboratory bridge with accuracy to 1/2%.

## DYNAMIC TUBE TESTER

(Continued from page 21)

of sockets to accommodate all types of receiver tubes in use, wired together according to standard pin numbering, with each of the nine possible contacts brought out to pin jacks or terminals on the panel. The sockets, transformer, meter and filament switch of an old emission tester could be adapted to the purpose.

### PATCH-CORD SYSTEM

This is essentially a technician's instrument and switching arrangements would be complicated and costly. Therefore, with the exception of the filament, no switching arrangement was considered. Instead pin jacks and pin tip leads are used to make the various connections externally. This gives the instrument complete flexibility and freedom from obsolescence unless new type sockets are brought out, at which time they could easily be added.

Referring to Figure 3, it will be seen that the instrument must be used with a tube manual for the application of proper voltages to the correct pins and to find the Sm to be expected under these conditions—unless the builder prefers to make a complete list of pin numbers, voltages and Sm to be expected. The writer found it simpler to enter the bias setting and Sm in the tube manual.

Calibration of new scales for the Sm meter is carried out with known good tubes. The procedure will vary with the type of D.C. milliammeter used. Let us assume that it is a 0-6 Ma. This should give us a range up to 6000  $\mu$ Mhos. First we must set R1 to apply one volt peak between cathode and grid. This should be measured with a V.T.V.M. if resistance of R1 is high. If one is not available calculate it from the output of T1 and the resistance ratio of R1:

$$E_g = \frac{x + y}{E_{tv}}$$

when  $E_g$  is signal output,  $E_{tv}$  is transformer output and equals 1.414 times voltage measured on ordinary meter; x and y are values in ohms either side of tap.

Insert a known good tube, say a 6C5, and

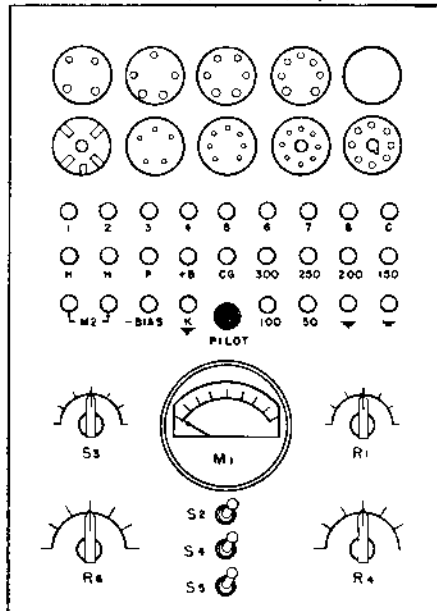

Panel layout of the transconductance meter is such as to promote speed and efficiency.

apply voltages for an Sm of 2000  $\mu$ Mhos. If the output circuit were completely efficient a reading of about 2 Ma. should be obtained. In any case, mark the scale for 2000  $\mu$ Mhos. Similarly, repeat with say a 6J5 for 3000  $\mu$ Mhos, a 27 for 1000, a 6V6 for 4000, and so on. By consulting the tube manual, tubes with other values can be chosen and different tubes with the same Sm used for a double-check of the calibration, which should be fairly linear.

Some constructors may prefer to put R1 on the front panel and log an arbitrary value for each tube which will give it the correct Sm reading to correspond to the manual data for given conditions. It should also be mentioned that the bias control R4 can be used to vary the output reading.

If a 1 or 2 Ma. meter is used it would be best to have two or even three scales, increasing the meter's range with a switch and shunts. In the case of a heavy current meter of 10 Ma. or more it would be advisable to increase the input signal voltage to give full scale deflection for a 6000  $\mu$ Mho reading. An Sm scale of 0-3000 will handle the great majority of tubes; in fact all but about twenty. A 0-6000  $\mu$ Mho scale will take care of all but nine, such as the 25L6 and 6Y6. The 1633 is highest with an Sm of 10,000. The builder can decide whether or not it is justifiable to extend the ranges in order to measure these tubes at their full rated value.

### CONSTANT VOLTAGE NEEDED

It is of course essential to hold all voltages constant, hence, rheostat R7, capable of dissipating 30 to 40 watts. If an A.C. voltmeter is not available to incorporate in the instrument, pin jacks can be provided to use an external one. Similarly, with the meter M1 which, if it belongs to a multi-tester, could not be calibrated directly. It would then be necessary to make a conversion chart for it.

Also note that it is necessary to use a center tapped resistor when checking filament type tubes or a 60-cycle voltage will be impressed on the grid (independent of T1), due to unbalance in the filament circuit. If the C.T. resistor is low in value it will have to be opened up by switch S2 for high filament voltage tubes, or it will burn out. If a high value is chosen to avoid this it will bias the tube.

No provision was made for emission or short tests since it would further complicate the circuit and it is assumed that a conventional emission tester is available for such tests. However, the output circuit could be modified as shown in Figure 2 to provide emission tests by throwing S1. The switch is double-pole double-throw type. When used for emission tests the meter shunt R6 is connected across the meter to give it a suitable range and the meter is inserted in series with the plate supply. Emission readings should correspond with manual data for given voltages. The meter should cover from a few mils to at least 60, and it may be desired to add another shunt and switch to give more easily read ranges.

Hooked up as straight emission tester, tubes can be checked quickly enough to permit its use in a commercial radio service shop. When more precise measurements are required, it becomes a transconductance tester with the flip of a switch.

## NOW—A REALLY HIGH-POWERED— Radio Engineering Library

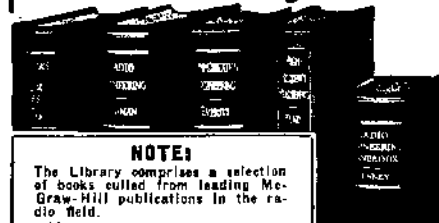

**NOTE:**  
The Library comprises a selection of books culled from leading McGraw-Hill publications in the radio field.

- especially selected by radio specialists of McGraw-Hill publications
- to give most complete, dependable coverage of facts needed by all whose fields are grounded on radio fundamentals
- available at a special price and terms

THESE books cover circuit phenomena, tube theory, networks, measurements, and other subjects—give specialized treatments of all fields of practical design and application. They are books of recognized position in the literature—books you will refer to and be referred to often. If you are a practical designer, researcher or engineer in any field based on radio, you want these books for the help they give in hundreds of problems throughout the whole field of radio engineering.

### 5 VOLUMES, 3319 PAGES, 2289 ILLUSTRATIONS

1. Eastman's FUNDAMENTALS OF VACUUM TUBES
2. Terman's RADIO ENGINEERING
3. Everitt's COMMUNICATION ENGINEERING
4. Hund's HIGH FREQUENCY MEASUREMENTS
5. Henney's RADIO ENGINEERING HANDBOOK

10 days' examination. Easy terms. Special price under this offer less than books bought separately. Add these standard works to your library now; pay small monthly installments, while you use the books.

10 DAYS' FREE EXAMINATION—SEND COUPON

McGraw-Hill Book Co., 330 W. 42nd St., New York 18

Send me the Radio Engineering Library, 5 vols., for 10 days' examination on approval. In 10 days I will send \$3.00, plus few cents postage, and \$3.00 monthly till \$24.00 is paid, or return books postpaid. (We pay postage on orders accompanied by remittance of first installment.)

Name .....

Address .....

City and State .....

Company .....

Position .....

RCL-45

To save pin jacks the writer used an insulated panel (Masonite) and drilled holes to take the pin tips, riveting springs to the back of the panel. Pin tips were made from heavy copper wire, insulated with tape. Since the operator may come in contact with 350 volts, it is advisable to break the plate supply with a switch, S4, while setting up for a test. Also, of course, care must be taken in making correct connections, or the tube might be damaged. Dual purpose tubes will require two or more separate tests.

If a tapped filament transformer is not available it can be wound on any power transformer with a good 110 v. primary. (When removing the old windings observe the number of turns per volt. If a 5 v. winding has 30 turns the transformer has 6 turns per volt. This can be used to compute where to tap off leads. In this case the 1.4 v. tap will be at  $6 \times 1.4 = 8.4$  turns and 6.3 v. at  $6 \times 6.3 = 37.8$  turns approximately.)

The dynamic tester is a most useful instrument and will well repay the builder in time saved, particularly when a replacement tube is not readily available for a substitution check, or a receiver for a check under operating conditions. At the same time it will save the rejection of low emission but otherwise good tubes.

This checker should be well worth the time and energy spent in constructing it.



# No. 1 Rule

For A Better Job and Security  
In Radio-Electronics

**Add CREI Technical Training to Your Present Experience—Then Get That Better Radio Job You Want—Enjoy Security!**



Thousands of new men joined the ranks of the radio industry during the war. Now, even more thousands are returning from the armed forces. Competition for the better technical jobs will be keen. Where will you fit into this picture?

If you are wise, you will take action now and *prepare for the good-paying jobs* in radio-electronics. Every man in radio today has the opportunity to see the amazing developments that are taking place, as well as the unlimited opportunities available to men with modern technical training.

It is up to you to decide if you will be a "screwdriver" mechanic or a *real technician* in a *responsible engineering position*.

CREI home study courses are constantly being revised and kept up-to-date with the rapid developments in the industry. What do you know today about U.H.F. circuits, cavity resonators, wave guides, Klystrons, Magnetrons and other tubes? U.H.F. as well as all other basic principles of modern, practical radio-electronics engineering are covered in CREI home study courses.

CREI can help you prepare by providing you with a *proved program of home study training* that will *increase your technical ability* and equip you to *advance to the better-paying radio jobs* that offer security and opportunity. The facts about CREI and what it can do for you are printed in a 36-page booklet. It is well worth your reading. *Send for it today.*

### Servicemen—

#### Discharged Veterans

**CREI Residence Training Available Under Provisions of "G.I." Bill**

CREI now offers Residence School courses in Radio-Electronics Engineering, Broadcast & Television Engineering and Broadcast & Television Servicing under the Serviceman's Readjustment Act of 1944 ("G.I." Bill.) Classes now in session. Enter at any time. Write for details.

## WRITE TODAY FOR FREE 36-PAGE BOOKLET

### "Your Opportunity in the New World of Electronics"

TELL US ALL ABOUT YOURSELF, so that we can intelligently plan a course best suited to your needs. If you have had professional or amateur radio experience — let us prove to you that we have something you need to qualify for a better radio job. To help us intelligently answer your inquiry—PLEASE STATE BRIEFLY YOUR BACKGROUND OF EXPERIENCE, EDUCATION AND PRESENT POSITION.



# CAPITOL RADIO Engineering Institute

HOME STUDY COURSES IN PRACTICAL RADIO-ELECTRONICS  
ENGINEERING FOR PROFESSIONAL SELF-IMPROVEMENT

**Dept. RC-14, 3224 — 16th Street, N. W., Washington 10, D. C.**

Contractors to U. S. Navy—U. S. Coast Guard—Canadian Broadcasting Corp.  
Producers of Well-trained Technical Radiomen for Industry.

Member: National Council of Technical Schools